



**APPROVALS**



**ENGINEERING CODE**  
211AC06

**APPROVED REFRIGERANT**  
R-134a

**POWER SUPPLY**  
220 V 50 Hz

**STANDARD CONDITIONS**  
EN12900

**APPLICATION**  
HBP

**COOLING CAPACITY**  
1431 W (HBP)

**EFFICIENCY**  
2.19 W/W (HBP)

**MOTOR TYPE**  
CSIR

**STARTING TORQUE**  
HST

**DATA**

**General Data**

Type	Hermetic reciprocating
Technology Type	On-Off
Displacement	17.39 cm <sup>3</sup>
Compressor Cooling	Fan/NotControlled/220
Fan Air Flow	520 m <sup>3</sup> /h
Expansion Device	Capillary Tube or Expansion Valve
Horse Power	1/2 hp
Max Condensing Pressure Operating	13.92 bar
Max Condensing Pressure Peak	15.62 bar
Power Supply	220 V 50 Hz
Evaporating Temperature Range	-15 °C to 10 °C

**Electrical Data**

Motor type	CSIR
Starting Torque	HST
Start Winding Resistance	19.25 Ω at 25° C
Run Winding Resistance	3 Ω at 25° C

## Mechanical Data

Maximum Recommended Refrigerant Charge	800 g
Oil Charge	450 ml
Oil Type Configuration	ESTER
Oil Type Viscosity	ISO22
Pressurization	Dry air charge
Weight	17 Kg
Free Internal Volume	3.3 L

## Electrical Components

	Description
Start Capacitor	64-77 Uf / 330 V
Motor Protection	T0634/G6
Starting Device	Relay   MTRP-0048*

## External Characteristics

Base Plate	Universal	
Tray Holder	No	
Height	207 mm	
Connector	Internal Diameter	Shape
Suction	9.6 mm	Slanted 42°/Copper
Discharge	6.42 mm	Straight/Copper
Process	6.42 mm	Vertical/Copper

## PERFORMANCE

## Rated Points

Condensing Temperature	Evaporating Temperature	Cooling Capacity	Power Consumption	Gas Flow Rate	Efficiency
50.00°C	5.00°C	1431 W	654 W	35.98 kg/h	2.19 W/W

Test Condition: EN12900HBP, Fan/NotControlled/220, Return Gas 20°C, Evaporation 5.00°C, Condensing 50.00°C, Ambient 35°C, Liquid 50°C, Subcooling 0K. Data are an indication of performance based simulation.

## Performance Curve Data

### Condensing Temperature 35°C

Evaporating Temperature °C	Cooling Capacity W	Power W	Gas Flow Rate kg/h	Efficiency W/W
-15	728	419	15.41	1.74
-10	932	455	19.83	2.05
-5	1177	488	25.15	2.41
0	1464	518	31.48	2.82
5	1796	545	38.92	3.29
10	2177	569	47.60	3.83

Test Condition: EN12900HBP, Fan/NotControlled/220, Return Gas 20°C, Ambient 35°C, Subcooling OK. Data are an indication of performance based simulation.

### Condensing Temperature 45°C

Evaporating Temperature °C	Cooling Capacity W	Power W	Gas Flow Rate kg/h	Efficiency W/W
-15	613	441	14.21	1.39
-10	796	488	18.56	1.63
-5	1013	533	23.77	1.9
0	1268	577	29.93	2.2
5	1561	620	37.17	2.52
10	1896	661	45.60	2.87

Test Condition: EN12900HBP, Fan/NotControlled/220, Return Gas 20°C, Ambient 35°C, Subcooling OK. Data are an indication of performance based simulation.

### Condensing Temperature 55°C

Evaporating Temperature °C	Cooling Capacity W	Power W	Gas Flow Rate kg/h	Efficiency W/W
-10	644	520	16.70	1.24
-5	836	572	21.80	1.46
0	1058	625	27.82	1.69
5	1313	679	34.86	1.94
10	1605	732	43.04	2.19

Test Condition: EN12900HBP, Fan/NotControlled/220, Return Gas 20°C, Ambient 35°C, Subcooling OK. Data are an indication of performance based simulation.

## Operating Envelope

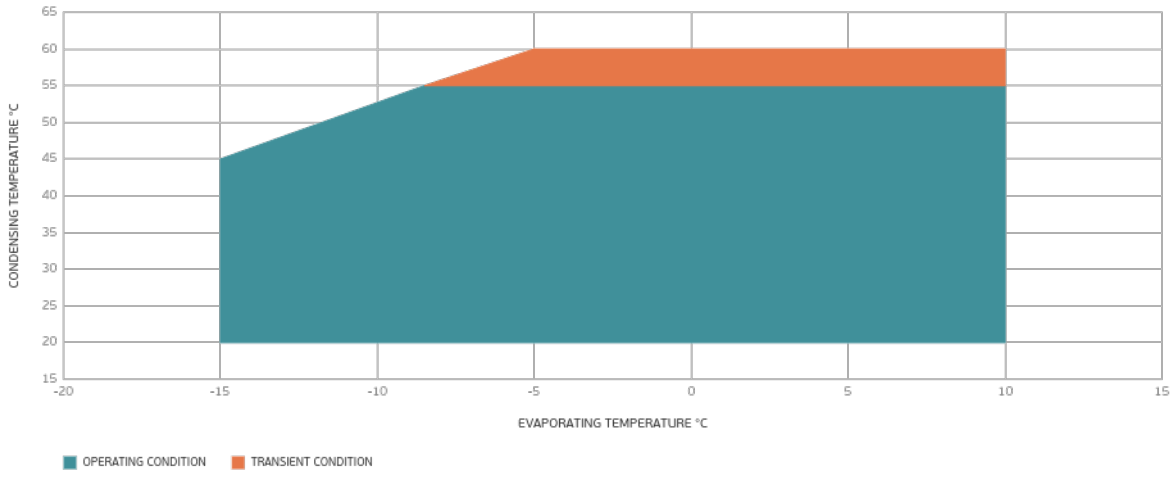

## External Dimensions

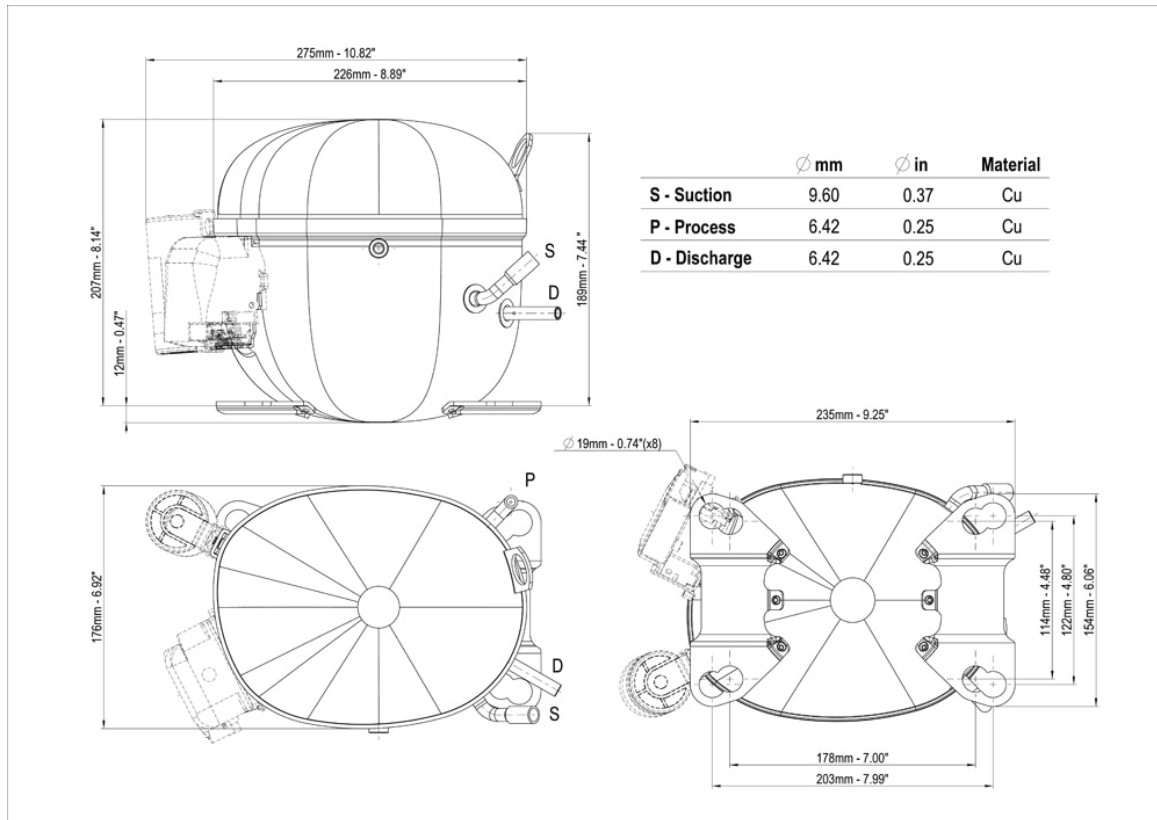

## Wiring Diagram



## Assembly Instructions

