



Compressor
Voltage Code : TZ

TFH2511Z

Low Temp. Commercial (BP)

400V 3~ 50Hz / 440V 3~ 60 Hz

R452A / R404A / R448A / R449A

AHC2490ZTZ

Conditions	Frequency	Nominal Cooling Capacity		Sound Power ISO3745 / ISO 3743-1
		Watts	BTU/h	
EN12900 / R452A	50 Hz / 60 Hz	1372 / 1719	4677 / 5863	77 dBA
EN12900 / R404A	50 Hz / 60 Hz	1490 / 1868	5080 / 6370	77 dBA
EN12900 / R448A	50 Hz / 60 Hz	1159 / 1454	3953 / 4958	77 dBA
EN12900 / R449A	50 Hz / 60 Hz	1159 / 1454	3953 / 4958	77 dBA

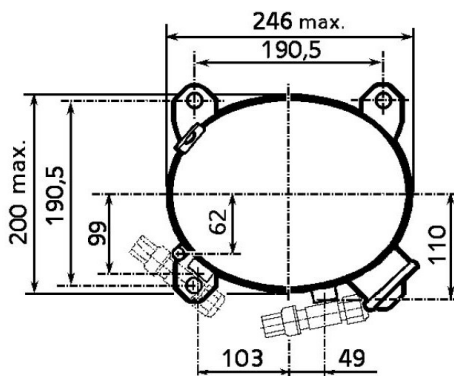
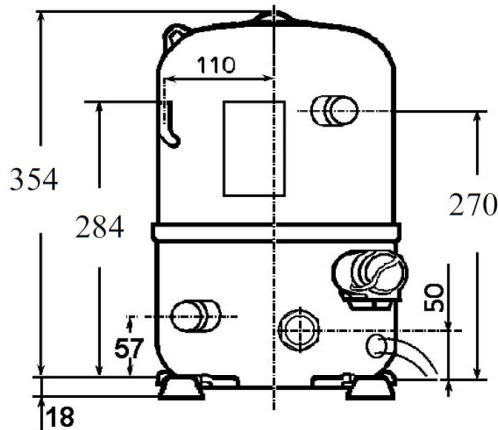

Displacement (cc)	74,2
Net Weight (Kg)	32,6
Oil Quantity (cc)	1330,0
Oil Type	Polyolester
Expansion Device	Capillary_Tube/Expansion_Valve
Cooling	Fan
Main Winding (Ohm)	5,1
Current	
RLA (A)	3,7 3,8
MCC (A)	7,2 7,2
LRA (A)	28 32
Electrical Equipment	TRI
Overload	Interne
Refrigerating connection for OD	
Suction Tube	15,9 (5/8")
Discharge Tube	12,7 (1/2")
Process Tube	6,35 (1/4")

* EN12900 : T°Cond. 40.0°C / T°Evap. -35.0°C / T°Return gas temp.. 20.0°C
T°Subcooling. 0.0K

Certificates :



Note : Tecumseh reserves the right to change information contained in this document without notification.



Tecumseh

TFH2511Z	Tension TZ : 400V 3~ 50Hz / 440V 3~ 60 Hz
-----------------	--

Les performances sont données dans les **conditions EN12900** :
 Condition Dew
 The performance data are in **EN12900 conditions** :
 Dew Condition

Gaz aspirés : 20.0 °C
 Sous refroidissement : 0.0 K
 Return gas : 20.0 °C
 Subcooling : 0.0 K

© 2021 Tecumseh Products Company
All rights reserved

50 Hz R452A

N°1123

4 T condensation	5 T évaporation	(°C)	-40	-35	-30	-25	-20	-15	-10
30	1 P frigorifique	(Watt)	1258	1839	2557	3427	4465	5688	7113
	2 P absorbée	(W)	1114	1344	1591	1860	2157	2487	2857
	3 I absorbée	(A)	2.64	2.88	3.16	3.50	3.89	4.34	4.84
40	1 P frigorifique	(Watt)	881	1372	1979	2720	3611	4668	5907
	2 P absorbée	(W)	1024	1281	1553	1846	2165	2516	2905
	3 I absorbée	(A)	2.53	2.82	3.15	3.53	3.96	4.45	4.99
50	1 P frigorifique	(Watt)		964	1460	2070	2810	3698	4750
	2 P absorbée	(W)		1202	1508	1832	2182	2562	2978
	3 I absorbée	(A)		2.72	3.10	3.53	4.00	4.52	5.09
60	1 P frigorifique	(Watt)				1494	2083	2800	3661
	2 P absorbée	(W)				1821	2209	2626	3077
	3 I absorbée	(A)				3.48	3.99	4.55	5.16

60 Hz R452A

N°1123

4 T condensation	5 T évaporation	(°C)	-40	-35	-30	-25	-20	-15	-10
30	1 P frigorifique	(Watt)	1568	2254	3043	3944	4966	6118	7411
	2 P absorbée	(W)	1378	1669	1944	2216	2501	2811	3161
	3 I absorbée	(A)	2.30	2.60	2.95	3.35	3.82	4.35	4.94
40	1 P frigorifique	(Watt)	1077	1719	2447	3270	4196	5237	6400
	2 P absorbée	(W)	1224	1605	1956	2294	2630	2981	3359
	3 I absorbée	(A)	2.25	2.61	3.02	3.49	4.02	4.60	5.25
50	1 P frigorifique	(Watt)		1132	1781	2508	3321	4231	5247
	2 P absorbée	(W)		1412	1856	2272	2676	3081	3501
	3 I absorbée	(A)		2.48	2.96	3.49	4.07	4.71	5.41
60	1 P frigorifique	(Watt)				1710	2392	3154	4004
	2 P absorbée	(W)				2126	2611	3086	3563
	3 I absorbée	(A)				3.34	3.98	4.67	5.41

1 = cooling capacity 2 = power input 3 = current 4 = condensing temperature 5 = evaporating temperature

Nota : Tecumseh se réserve le droit de modifier les informations contenues dans ce document sans préavis.

Note : Tecumseh reserves the right to change information contained in this document without notification.



Tecumseh

TFH2511Z	Tension TZ : 400V 3~ 50Hz / 440V 3~ 60 Hz
-----------------	--

Les performances sont données dans les conditions EN12900 :	Gaz aspirés :	20.0 °C
Condition Dew	Sous refroidissement :	0.0 K
The performance data are in EN12900 conditions :	Return gas :	20.0 °C
Dew Condition	Subcooling :	0.0 K

© 2021 Tecumseh Products Company
All rights reserved

50 Hz R404A

N°126LU-T

4 T condensation	5 T évaporation	(°C)	-40	-35	-30	-25	-20	-15	-10
30	1 P frigorigère	(Watt)	1379	1999	2756	3663	4732	5976	7407
	2 P absorbée	(W)	1193	1443	1708	1992	2300	2637	3009
	3 I absorbée	(A)	2.83	3.09	3.39	3.75	4.15	4.60	5.10
40	1 P frigorigère	(Watt)	971	1490	2124	2887	3791	4849	6073
	2 P absorbée	(W)	1116	1388	1675	1980	2310	2668	3061
	3 I absorbée	(A)	2.76	3.05	3.40	3.79	4.23	4.72	5.26
50	1 P frigorigère	(Watt)		1050	1565	2188	2931	3807	4827
	2 P absorbée	(W)		1319	1637	1974	2334	2724	3147
	3 I absorbée	(A)		2.99	3.37	3.80	4.28	4.81	5.38
60	1 P frigorigère	(Watt)			1079	1566	2152	2848	3669
	2 P absorbée	(W)			1597	1975	2376	2806	3269
	3 I absorbée	(A)			3.31	3.78	4.30	4.86	5.48

60 Hz R404A

N°126LU-T

4 T condensation	5 T évaporation	(°C)	-40	-35	-30	-25	-20	-15	-10
30	1 P frigorigère	(Watt)	1719	2450	3280	4215	5262	6427	7717
	2 P absorbée	(W)	1475	1791	2086	2373	2666	2981	3330
	3 I absorbée	(A)	2.47	2.79	3.16	3.59	4.07	4.61	5.20
40	1 P frigorigère	(Watt)	1188	1868	2627	3471	4406	5440	6580
	2 P absorbée	(W)	1334	1738	2109	2460	2806	3161	3539
	3 I absorbée	(A)	2.45	2.83	3.26	3.75	4.29	4.88	5.53
50	1 P frigorigère	(Watt)		1233	1909	2651	3464	4355	5332
	2 P absorbée	(W)		1549	2014	2447	2863	3276	3700
	3 I absorbée	(A)		2.72	3.21	3.76	4.36	5.01	5.71
60	1 P frigorigère	(Watt)			1165	1792	2472	3209	4012
	2 P absorbée	(W)			1773	2306	2809	3297	3785
	3 I absorbée	(A)			3.02	3.62	4.28	4.99	5.75

1 = cooling capacity 2 = power input 3 = current 4 = condensing temperature 5 = evaporating temperature

Nota : Tecumseh se réserve le droit de modifier les informations contenues dans ce document sans préavis.

Note : Tecumseh reserves the right to change information contained in this document without notification.



Tecumseh

TFH2511Z	Tension TZ : 400V 3~ 50Hz / 440V 3~ 60 Hz
-----------------	--

Les performances sont données dans les conditions EN12900 :	Gaz aspirés :	20.0 °C
Condition Dew	Sous refroidissement :	0.0 K
The performance data are in EN12900 conditions :	Return gas :	20.0 °C
Dew Condition	Subcooling :	0.0 K

50 Hz R448A (*)								
N°2773								
4 T condensation	5 T évaporation	(°C)	-35	-30	-25	-20	-15	-10
30	1 P frigorifique	(Watt)	1558	2257	3119	4160	5396	6843
	2 P absorbée	(W)	1247	1489	1752	2039	2358	2714
	3 I absorbée	(A)	2.67	2.96	3.30	3.68	4.11	4.60
40	1 P frigorifique	(Watt)	1159	1746	2478	3371	4442	5707
	2 P absorbée	(W)	1204	1468	1749	2052	2383	2749
	3 I absorbée	(A)	2.65	2.98	3.35	3.76	4.21	4.72
50	1 P frigorifique	(Watt)	824	1309	1922	2679	3596	4689
	2 P absorbée	(W)	1140	1439	1752	2084	2442	2831
	3 I absorbée	(A)	2.58	2.96	3.37	3.82	4.31	4.84
60	1 P frigorifique	(Watt)			1470	2102	2876	3808
	2 P absorbée	(W)			1751	2127	2525	2952
	3 I absorbée	(A)			3.35	3.84	4.38	4.95

60 Hz R448A (*)								
N°2773								
4 T condensation	5 T évaporation	(°C)	-35	-30	-25	-20	-15	-10
30	1 P frigorifique	(Watt)	1909	2685	3589	4627	5804	7128
	2 P absorbée	(W)	1548	1819	2087	2364	2665	3003
	3 I absorbée	(A)	2.41	2.76	3.16	3.61	4.12	4.69
40	1 P frigorifique	(Watt)	1454	2161	2981	3920	4985	6182
	2 P absorbée	(W)	1508	1849	2173	2493	2824	3178
	3 I absorbée	(A)	2.45	2.86	3.31	3.81	4.36	4.96
50	1 P frigorifique	(Watt)	966	1599	2329	3165	4113	5179
	2 P absorbée	(W)	1339	1770	2171	2555	2937	3329
	3 I absorbée	(A)	2.36	2.82	3.33	3.89	4.49	5.14
60	1 P frigorifique	(Watt)			1682	2410	3236	4165
	2 P absorbée	(W)			2045	2514	2967	3418
	3 I absorbée	(A)			3.21	3.83	4.49	5.19

1 = cooling capacity 2 = power input 3 = current 4 = condensing temperature 5 = evaporating temperature

(*) Veuillez vous référer strictement aux Recommandations d'Utilisation et Bulletins Marketing Tecumseh du fait de la température de reflux élevée pour les applications LBP.
 (*) Due to very high discharge temperature especially on LBP conditions, please strictly refer to Tecumseh Guidelines & Marketing Bulletin when using this refrigerant.

Nota : Tecumseh se réserve le droit de modifier les informations contenues dans ce document sans préavis.

Note : Tecumseh reserves the right to change information contained in this document without notification.

© 2021 Tecumseh Products Company
All rights reserved



Tecumseh

TFH2511Z	Tension TZ : 400V 3~ 50Hz / 440V 3~ 60 Hz
-----------------	--

Les performances sont données dans les conditions EN12900 :	Gaz aspirés :	20.0 °C
Condition Dew	Sous refroidissement :	0.0 K
The performance data are in EN12900 conditions :	Return gas :	20.0 °C
Dew Condition	Subcooling :	0.0 K

50 Hz R449A (*)								
N°2032								
4 T condensation	5 T évaporation	(°C)	-35	-30	-25	-20	-15	-10
30	1 P frigorifique	(Watt)	1558	2257	3119	4160	5396	6843
	2 P absorbée	(W)	1247	1489	1752	2039	2358	2714
	3 I absorbée	(A)	2.67	2.96	3.30	3.68	4.11	4.60
40	1 P frigorifique	(Watt)	1159	1746	2478	3371	4442	5707
	2 P absorbée	(W)	1204	1468	1749	2052	2383	2749
	3 I absorbée	(A)	2.65	2.98	3.35	3.76	4.21	4.72
50	1 P frigorifique	(Watt)	824	1309	1922	2679	3596	4689
	2 P absorbée	(W)	1140	1439	1752	2084	2442	2831
	3 I absorbée	(A)	2.58	2.96	3.37	3.82	4.31	4.84
60	1 P frigorifique	(Watt)			1470	2102	2876	3808
	2 P absorbée	(W)			1751	2127	2525	2952
	3 I absorbée	(A)			3.35	3.84	4.38	4.95

60 Hz R449A (*)								
N°2032								
4 T condensation	5 T évaporation	(°C)	-35	-30	-25	-20	-15	-10
30	1 P frigorifique	(Watt)	1909	2685	3589	4627	5804	7128
	2 P absorbée	(W)	1548	1819	2087	2364	2665	3003
	3 I absorbée	(A)	2.41	2.76	3.16	3.61	4.12	4.69
40	1 P frigorifique	(Watt)	1454	2161	2981	3920	4985	6182
	2 P absorbée	(W)	1508	1849	2173	2493	2824	3178
	3 I absorbée	(A)	2.45	2.86	3.31	3.81	4.36	4.96
50	1 P frigorifique	(Watt)	966	1599	2329	3165	4113	5179
	2 P absorbée	(W)	1339	1770	2171	2555	2937	3329
	3 I absorbée	(A)	2.36	2.82	3.33	3.89	4.49	5.14
60	1 P frigorifique	(Watt)			1682	2410	3236	4165
	2 P absorbée	(W)			2045	2514	2967	3418
	3 I absorbée	(A)			3.21	3.83	4.49	5.19

1 = cooling capacity 2 = power input 3 = current 4 = condensing temperature 5 = evaporating temperature

(*) Veuillez vous référer strictement aux Recommandations d'Utilisation et Bulletins Marketing Tecumseh du fait de la température de reflux élevée pour les applications LBP.
 (*) Due to very high discharge temperature especially on LBP conditions, please strictly refer to Tecumseh Guidelines & Marketing Bulletin when using this refrigerant.

Nota : Tecumseh se réserve le droit de modifier les informations contenues dans ce document sans préavis.

Note : Tecumseh reserves the right to change information contained in this document without notification.

© 2021 Tecumseh Products Company
All rights reserved