



Tecumseh

Compressor
Voltage Code : TZ

TAG4561Z

High Temp. Commercial (HP)

400V 3~ 50Hz / 440V 3~ 60 Hz

R452A / R404A / R448A / R449A

AGB4561ZTZ

Conditions	Frequency	Nominal Cooling Capacity		Sound Power ISO3745 / ISO 3743-1
		Watts	BTU/h	
EN12900_MHP / R452A	50 Hz / 60 Hz	6910 / 8727	23563 / 29758	83 dBA
EN12900_MHP / R404A	50 Hz / 60 Hz	7107 / 8975	24235 / 30606	83 dBA
EN12900_MHP / R448A	50 Hz / 60 Hz	6560 / 8284	22369 / 28249	83 dBA
EN12900_MHP / R449A	50 Hz / 60 Hz	6560 / 8284	22369 / 28249	83 dBA

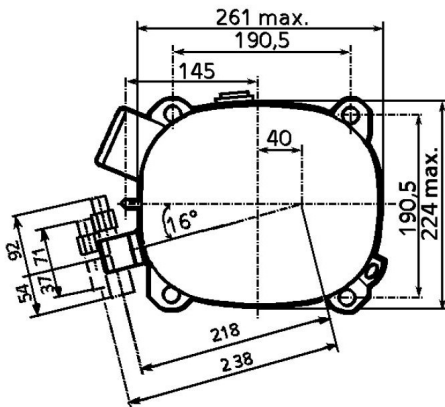
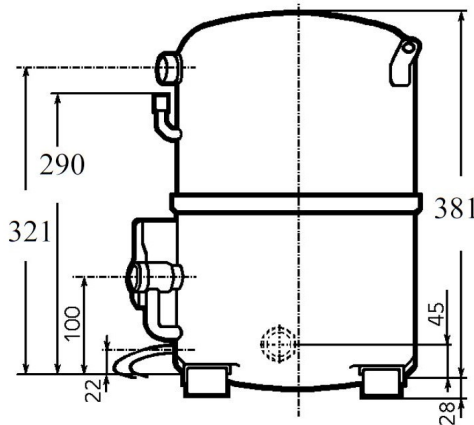

Displacement (cc)	112,5
Net Weight (Kg)	46.0
Oil Quantity (cc)	1760.0
Oil Type	Polyolester
Expansion Device	Capillary_Tube/Expansion_Valve
Cooling	Fan
Main Winding (Ohm)	3.2
Current	
RLA (A)	9.2 9.6
MCC (A)	15.3 14.7
LRA (A)	50 52
Electrical Equipment	TRI
Overload	Interne
Refrigerating connection for OD	
Suction Tube	28.6 (1"1/8)
Discharge Tube	15.9 (5/8")
Process Tube	6.35 (1/4")

* EN12900_MHP : T°Cond. 45.0°C / T°Evap. -10.0°C / T°Return gas temp.. 20.0°C
T°Subcooling. 0.0K

Certificates :



Note : Tecumseh reserves the right to change information contained in this document without notification.



Tecumseh

TAG4561Z	Tension TZ : 400V 3~ 50Hz / 440V 3~ 60 Hz
-----------------	--

Les performances sont données dans les conditions EN12900_MHP :	Gaz aspirés :	20.0 °C
Condition Dew	Sous refroidissement :	0.0 K
The performance data are in EN12900_MHP conditions :	Return gas :	20.0 °C
Dew Condition	Subcooling :	0.0 K

50 Hz R452A											
											N°2146
4 T condensation	5 T évaporation	(°C)	-25	-20	-15	-10	-5	0	5	10	15
30	1 P frigorifique	(Watt)	4161	5682	7512	9705	12311	15382	18970	23127	27904
	2 P absorbée	(W)	2257	2636	3000	3364	3744	4155	4613	5132	5729
	3 I absorbée	(A)	4.17	4.61	5.07	5.55	6.06	6.60	7.16	7.75	8.36
40	1 P frigorifique	(Watt)		4361	5964	7837	10032	12601	15594	19064	23063
	2 P absorbée	(W)		2654	3107	3542	3973	4417	4887	5401	5973
	3 I absorbée	(A)		4.60	5.15	5.72	6.33	6.95	7.61	8.29	9.00
50	1 P frigorifique	(Watt)			4393	5980	7797	9896	12328	15144	18398
	2 P absorbée	(W)			3085	3626	4145	4657	5177	5721	6304
	3 I absorbée	(A)			5.15	5.82	6.51	7.24	7.99	8.76	9.57
60	1 P frigorifique	(Watt)				4094	5567	7229	9133	11329	13870
	2 P absorbée	(W)				3557	4200	4817	5423	6033	6664
	3 I absorbée	(A)				5.83	6.62	7.44	8.29	9.16	10.1

60 Hz R452A											
											N°2146
4 T condensation	5 T évaporation	(°C)	-25	-20	-15	-10	-5	0	5	10	15
30	1 P frigorifique	(Watt)	5296	7189	9499	12192	15235	18595	22238	26131	30241
	2 P absorbée	(W)	2828	3342	3853	4372	4914	5493	6122	6815	7585
	3 I absorbée	(A)	4.55	5.24	5.97	6.74	7.55	8.40	9.29	10.2	11.2
40	1 P frigorifique	(Watt)		5551	7518	9855	12528	15503	18748	22228	25910
	2 P absorbée	(W)		3324	3930	4522	5115	5722	6357	7033	7764
	3 I absorbée	(A)		5.23	6.03	6.87	7.75	8.66	9.62	10.6	11.7
50	1 P frigorifique	(Watt)			5624	7588	9873	12447	15276	18326	21564
	2 P absorbée	(W)			3862	4577	5270	5954	6643	7351	8091
	3 I absorbée	(A)			5.99	6.90	7.85	8.83	9.86	10.9	12.1
60	1 P frigorifique	(Watt)				5166	7047	9202	11598	14202	16979
	2 P absorbée	(W)				4428	5269	6078	6871	7659	8458
	3 I absorbée	(A)				6.83	7.85	8.91	10.0	11.2	12.3

1 = cooling capacity 2 = power input 3 = current 4 = condensing temperature 5 = evaporating temperature

Nota : Tecumseh se réserve le droit de modifier les informations contenues dans ce document sans préavis.

Note : Tecumseh reserves the right to change information contained in this document without notification.

© 2021 Tecumseh Products Company
All rights reserved



Tecumseh

TAG4561Z	Tension TZ : 400V 3~ 50Hz / 440V 3~ 60 Hz
-----------------	--

Les performances sont données dans les conditions EN12900_MHP :	Gaz aspirés :	20.0 °C
Condition Dew	Sous refroidissement :	0.0 K
The performance data are in EN12900_MHP conditions :	Return gas :	20.0 °C
Dew Condition	Subcooling :	0.0 K

© 2021 Tecumseh Products Company
All rights reserved

50 Hz R404A

N°227GU-T

4 T condensation	5 T évaporation	(°C)	-25	-20	-15	-10	-5	0	5	10	15
30	1 P frigorifique	(Watt)	4437	5990	7847	10057	12669	15732	19295	23405	28113
	2 P absorbée	(W)	2391	2781	3154	3525	3911	4324	4782	5300	5891
	3 I absorbée	(A)	4.42	4.86	5.33	5.82	6.33	6.86	7.42	8.00	8.60
40	1 P frigorifique	(Watt)	3185	4594	6210	8083	10261	12793	15728	19115	23001
	2 P absorbée	(W)	2312	2813	3276	3717	4153	4597	5064	5572	6133
	3 I absorbée	(A)	4.34	4.87	5.43	6.01	6.61	7.23	7.88	8.55	9.24
50	1 P frigorifique	(Watt)		3147	4560	6133	7914	9953	12297	14997	18100
	2 P absorbée	(W)		2679	3269	3817	4338	4848	5362	5896	6464
	3 I absorbée	(A)		4.80	5.45	6.12	6.82	7.53	8.27	9.03	9.81
60	1 P frigorifique	(Watt)			2864	4173	5595	7177	8969	11018	13375
	2 P absorbée	(W)			3075	3765	4409	5022	5618	6214	6824
	3 I absorbée	(A)			5.40	6.17	6.95	7.76	8.59	9.44	10.3

60 Hz R404A

N°227GU-T

4 T condensation	5 T évaporation	(°C)	-25	-20	-15	-10	-5	0	5	10	15
30	1 P frigorifique	(Watt)	5645	7582	9924	12635	15679	19019	22621	26448	30464
	2 P absorbée	(W)	2996	3526	4051	4581	5132	5716	6347	7037	7800
	3 I absorbée	(A)	4.82	5.53	6.28	7.07	7.89	8.74	9.63	10.6	11.5
40	1 P frigorifique	(Watt)	4250	5846	7829	10163	12812	15740	18911	22288	25837
	2 P absorbée	(W)	2872	3523	4143	4746	5346	5955	6587	7256	7973
	3 I absorbée	(A)	4.77	5.55	6.36	7.21	8.09	9.01	9.97	11.0	12.0
50	1 P frigorifique	(Watt)		4234	5842	7782	10019	12517	15239	18150	21214
	2 P absorbée	(W)		3328	4093	4817	5515	6198	6880	7575	8296
	3 I absorbée	(A)		5.47	6.35	7.26	8.21	9.20	10.2	11.3	12.4
60	1 P frigorifique	(Watt)			3742	5271	7079	9129	11387	13814	16377
	2 P absorbée	(W)			3794	4688	5531	6337	7119	7889	8662
	3 I absorbée	(A)			6.25	7.23	8.24	9.29	10.4	11.5	12.6

1 = cooling capacity 2 = power input 3 = current 4 = condensing temperature 5 = evaporating temperature

Nota : Tecumseh se réserve le droit de modifier les informations contenues dans ce document sans préavis.

Note : Tecumseh reserves the right to change information contained in this document without notification.



Tecumseh

TAG4561Z	Tension TZ : 400V 3~ 50Hz / 440V 3~ 60 Hz
-----------------	--

Les performances sont données dans les conditions EN12900_MHP :	Gaz aspirés :	20.0 °C
Condition Dew	Sous refroidissement :	0.0 K
The performance data are in EN12900_MHP conditions :	Return gas :	20.0 °C
Dew Condition	Subcooling :	0.0 K

50 Hz R448A (*)											
											N°2869
4 T condensation	5 T évaporation	(°C)	-25	-20	-15	-10	-5	0	5	10	15
30	1 P frigorifique	(Watt)	3666	5132	6910	9055	11625	14678	18269	22455	27294
	2 P absorbée	(W)	2104	2453	2794	3141	3506	3902	4340	4833	5394
	3 I absorbée	(A)	3.89	4.29	4.72	5.19	5.68	6.19	6.73	7.29	7.87
40	1 P frigorifique	(Watt)		3958	5529	7384	9582	12178	15230	18795	22929
	2 P absorbée	(W)		2492	2916	3326	3737	4161	4609	5094	5628
	3 I absorbée	(A)		4.32	4.83	5.38	5.95	6.55	7.17	7.82	8.48
50	1 P frigorifique	(Watt)			4133	5740	7605	9786	12340	15323	18793
	2 P absorbée	(W)			2914	3432	3933	4429	4931	5452	6004
	3 I absorbée	(A)			4.86	5.51	6.18	6.88	7.60	8.35	9.12
60	1 P frigorifique	(Watt)				4103	5677	7484	9580	12023	14869
	2 P absorbée	(W)				3377	4012	4623	5223	5825	6439
	3 I absorbée	(A)				5.53	6.32	7.14	7.98	8.85	9.73

60 Hz R448A (*)											
											N°2869
4 T condensation	5 T évaporation	(°C)	-25	-20	-15	-10	-5	0	5	10	15
30	1 P frigorifique	(Watt)	4671	6489	8734	11377	14390	17744	21413	25368	29581
	2 P absorbée	(W)	2637	3109	3587	4082	4602	5158	5760	6418	7142
	3 I absorbée	(A)	4.24	4.88	5.56	6.30	7.07	7.89	8.74	9.63	10.5
40	1 P frigorifique	(Watt)		5038	6967	9286	11968	14985	18309	21911	25765
	2 P absorbée	(W)		3122	3687	4247	4811	5390	5994	6633	7316
	3 I absorbée	(A)		4.92	5.66	6.45	7.28	8.16	9.07	10.0	11.0
50	1 P frigorifique	(Watt)			5285	7280	9632	12311	15289	18539	22033
	2 P absorbée	(W)			3649	4333	5001	5662	6326	7004	7706
	3 I absorbée	(A)			5.66	6.53	7.45	8.40	9.39	10.4	11.5
60	1 P frigorifique	(Watt)				5173	7194	9534	12167	15065	18199
	2 P absorbée	(W)				4202	5032	5834	6619	7395	8174
	3 I absorbée	(A)				6.48	7.49	8.55	9.64	10.8	11.9

1 = cooling capacity 2 = power input 3 = current 4 = condensing temperature 5 = evaporating temperature

(*) Veuillez vous référer strictement aux Recommandations d'Utilisation et Bulletins Marketing Tecumseh du fait de la température de refoulement élevée pour les applications LBP.
 (*) Due to very high discharge temperature especially on LBP conditions, please strictly refer to Tecumseh Guidelines & Marketing Bulletin when using this refrigerant.

Nota : Tecumseh se réserve le droit de modifier les informations contenues dans ce document sans préavis.

Note : Tecumseh reserves the right to change information contained in this document without notification.

© 2021 Tecumseh Products Company
All rights reserved



Tecumseh

TAG4561Z	Tension TZ : 400V 3~ 50Hz / 440V 3~ 60 Hz
-----------------	--

Les performances sont données dans les conditions EN12900_MHP :	Gaz aspirés :	20.0 °C
Condition Dew	Sous refroidissement :	0.0 K
The performance data are in EN12900_MHP conditions :	Return gas :	20.0 °C
Dew Condition	Subcooling :	0.0 K

50 Hz R449A (*)											
											N°2262
4 T condensation	5 T évaporation	(°C)	-25	-20	-15	-10	-5	0	5	10	15
30	1 P frigorifique	(Watt)	3666	5132	6910	9055	11625	14678	18269	22455	27294
	2 P absorbée	(W)	2104	2453	2794	3141	3506	3902	4340	4833	5394
	3 I absorbée	(A)	3.89	4.29	4.72	5.19	5.68	6.19	6.73	7.29	7.87
40	1 P frigorifique	(Watt)		3958	5529	7384	9582	12178	15230	18795	22929
	2 P absorbée	(W)		2492	2916	3326	3737	4161	4609	5094	5628
	3 I absorbée	(A)		4.32	4.83	5.38	5.95	6.55	7.17	7.82	8.48
50	1 P frigorifique	(Watt)			4133	5740	7605	9786	12340	15323	18793
	2 P absorbée	(W)			2914	3432	3933	4429	4931	5452	6004
	3 I absorbée	(A)			4.86	5.51	6.18	6.88	7.60	8.35	9.12
60	1 P frigorifique	(Watt)				4103	5677	7484	9580	12023	14869
	2 P absorbée	(W)				3377	4012	4623	5223	5825	6439
	3 I absorbée	(A)				5.53	6.32	7.14	7.98	8.85	9.73

60 Hz R449A (*)											
											N°2262
4 T condensation	5 T évaporation	(°C)	-25	-20	-15	-10	-5	0	5	10	15
30	1 P frigorifique	(Watt)	4671	6489	8734	11377	14390	17744	21413	25368	29581
	2 P absorbée	(W)	2637	3109	3587	4082	4602	5158	5760	6418	7142
	3 I absorbée	(A)	4.24	4.88	5.56	6.30	7.07	7.89	8.74	9.63	10.5
40	1 P frigorifique	(Watt)		5038	6967	9286	11968	14985	18309	21911	25765
	2 P absorbée	(W)		3122	3687	4247	4811	5390	5994	6633	7316
	3 I absorbée	(A)		4.92	5.66	6.45	7.28	8.16	9.07	10.0	11.0
50	1 P frigorifique	(Watt)			5285	7280	9632	12311	15289	18539	22033
	2 P absorbée	(W)			3649	4333	5001	5662	6326	7004	7706
	3 I absorbée	(A)			5.66	6.53	7.45	8.40	9.39	10.4	11.5
60	1 P frigorifique	(Watt)				5173	7194	9534	12167	15065	18199
	2 P absorbée	(W)				4202	5032	5834	6619	7395	8174
	3 I absorbée	(A)				6.48	7.49	8.55	9.64	10.8	11.9

1 = cooling capacity 2 = power input 3 = current 4 = condensing temperature 5 = evaporating temperature

(*) Veuillez vous référer strictement aux Recommandations d'Utilisation et Bulletins Marketing Tecumseh du fait de la température de reflux élevée pour les applications LBP.
 (*) Due to very high discharge temperature especially on LBP conditions, please strictly refer to Tecumseh Guidelines & Marketing Bulletin when using this refrigerant.

Nota : Tecumseh se réserve le droit de modifier les informations contenues dans ce document sans préavis.

Note : Tecumseh reserves the right to change information contained in this document without notification.

© 2021 Tecumseh Products Company
All rights reserved