



Compressor  
Voltage Code : TZ

TAG4581Z

High Temp. Commercial (HP)

400V 3~ 50Hz / 440V 3~ 60 Hz

R452A / R404A / R448A / R449A

AGB4581ZTZ

Conditions	Frequency	Nominal Cooling Capacity		Sound Power ISO3745 / ISO 3743-1
		Watts	BTU/h	
EN12900_HP / R452A	50 Hz / 60 Hz	16610 / 19468	56641 / 66384	84 dBA
EN12900_HP / R404A	50 Hz / 60 Hz	16569 / 19419	56501 / 66219	84 dBA
EN12900_HP / R448A	50 Hz / 60 Hz	16626 / 19487	56696 / 66451	84 dBA
EN12900_HP / R449A	50 Hz / 60 Hz	16626 / 19487	56696 / 66451	84 dBA

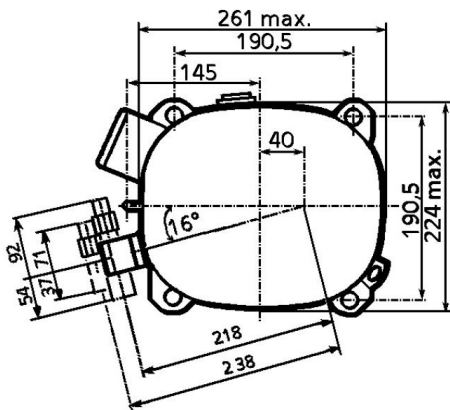
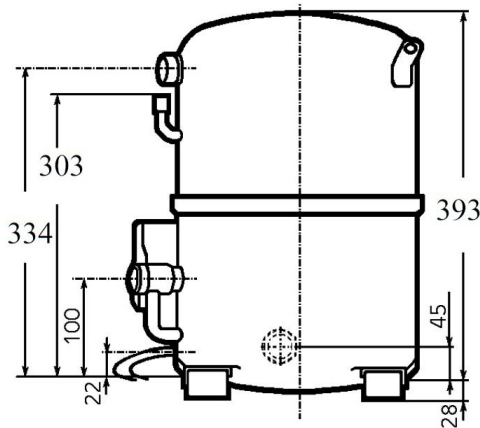

Displacement (cc)	145
Net Weight (Kg)	48.1
Oil Quantity (cc)	1760.0
Oil Type	Polyolester
Expansion Device	Capillary_Tube/Expansion_Valve
Cooling	Fan
Main Winding (Ohm)	1.63
<b>Current</b>	
RLA (A)	12.7   13.9
MCC (A)	20.8   21.4
LRA (A)	83   85
<b>Electrical Equipment</b>	TRI
<b>Overload</b>	Interne
<b>Refrigerating connection for OD</b>	
Suction Tube	28.6 (1"1/8)
Discharge Tube	15.9 (5/8")
Process Tube	6.35 (1/4")

\* EN12900\_HP : T°Cond. 50.0°C / T°Evap. 5.0°C / T°Return gas temp.. 20.0°C  
T°Subcooling. 0.0K

Certificates :



Note : Tecumseh reserves the right to change information contained in this document without notification.



**Tecumseh**

<b>TAG4581Z</b>	<b>Tension TZ : 400V 3~ 50Hz / 440V 3~ 60 Hz</b>
-----------------	--

Les performances sont données dans les **conditions EN12900\_HP** :  
 Condition Dew  
 The performance data are in **EN12900\_HP conditions** :  
 Dew Condition

Gaz aspirés : 20.0 °C  
 Sous refroidissement : 0.0 K  
 Return gas : 20.0 °C  
 Subcooling : 0.0 K

© 2021 Tecumseh Products Company  
All rights reserved

**50 Hz R452A**

**N°2158**

4   T condensation	5   T évaporation	(°C)	-25	-20	-15	-10	-5	0	5	10	15
<b>30</b>	1   P frigorifique	(Watt)	6133	8066	10337	12997	16099	19692	23829	28560	33937
	2   P absorbée	(W)	3373	3866	4327	4774	5222	5687	6186	6734	7348
	3   I absorbée	(A)	6.76	7.25	7.77	8.33	8.91	9.52	10.2	10.9	11.6
<b>40</b>	1   P frigorifique	(Watt)		6532	8577	10925	13626	16733	20296	24366	28995
	2   P absorbée	(W)		3950	4533	5083	5614	6144	6687	7261	7882
	3   I absorbée	(A)		7.36	8.00	8.68	9.39	10.1	10.9	11.7	12.6
<b>50</b>	1   P frigorifique	(Watt)			6711	8734	11024	13633	16610	20008	23878
	2   P absorbée	(W)			4593	5280	5930	6559	7183	7818	8480
	3   I absorbée	(A)			8.14	8.95	9.79	10.7	11.6	12.5	13.5
<b>60</b>	1   P frigorifique	(Watt)				6432	8300	10398	12779	15493	18592
	2   P absorbée	(W)				5321	6124	6887	7626	8356	9095
	3   I absorbée	(A)				9.12	10.1	11.1	12.1	13.2	14.3

**60 Hz R452A**

**N°2158**

4   T condensation	5   T évaporation	(°C)	-25	-20	-15	-10	-5	0	5	10	15
<b>30</b>	1   P frigorifique	(Watt)	7258	9498	12070	15034	18452	22387	26900	32052	37906
	2   P absorbée	(W)	4092	4705	5303	5910	6552	7253	8040	8936	9967
	3   I absorbée	(A)	6.50	7.22	7.97	8.75	9.56	10.4	11.3	12.2	13.2
<b>40</b>	1   P frigorifique	(Watt)		7827	10204	12886	15936	19415	23385	27907	33045
	2   P absorbée	(W)		4840	5567	6271	6979	7714	8503	9369	10339
	3   I absorbée	(A)		7.35	8.23	9.14	10.1	11.1	12.1	13.1	14.2
<b>50</b>	1   P frigorifique	(Watt)			8126	10479	13112	16088	19468	23313	27686
	2   P absorbée	(W)			5666	6533	7371	8206	9062	9964	10938
	3   I absorbée	(A)			8.40	9.44	10.5	11.6	12.8	14.0	15.2
<b>60</b>	1   P frigorifique	(Watt)				7884	10054	12479	15221	18342	21904
	2   P absorbée	(W)				6576	7609	8608	9596	10599	11642
	3   I absorbée	(A)				9.65	10.9	12.1	13.4	14.7	16.1

1 = cooling capacity 2 = power input 3 = current 4 = condensing temperature 5 = evaporating temperature

**Nota : Tecumseh se réserve le droit de modifier les informations contenues dans ce document sans préavis.**

**Note : Tecumseh reserves the right to change information contained in this document without notification.**



**Tecumseh**

<b>TAG4581Z</b>	<b>Tension TZ : 400V 3~ 50Hz / 440V 3~ 60 Hz</b>
-----------------	--

Les performances sont données dans les **conditions EN12900\_HP** :  
 Condition Dew  
 The performance data are in **EN12900\_HP conditions** :  
 Dew Condition

Gaz aspirés : 20.0 °C  
 Sous refroidissement : 0.0 K  
 Return gas : 20.0 °C  
 Subcooling : 0.0 K

© 2021 Tecumseh Products Company  
All rights reserved

**50 Hz R404A**

**N°227MU-T**

4   T condensation	5   T évaporation	(°C)	-25	-20	-15	-10	-5	0	5	10	15
<b>30</b>	1   P frigorifique	(Watt)	6540	8504	10797	13470	16568	20141	24237	28904	34190
	2   P absorbée	(W)	3573	4078	4549	5003	5454	5919	6413	6954	7556
	3   I absorbée	(A)	7.16	7.65	8.17	8.72	9.30	9.91	10.5	11.2	11.9
<b>40</b>	1   P frigorifique	(Watt)	5068	6881	8931	11267	13937	16989	20471	24431	28918
	2   P absorbée	(W)	3539	4186	4779	5334	5867	6393	6929	7491	8094
	3   I absorbée	(A)	7.18	7.80	8.44	9.11	9.82	10.5	11.3	12.1	12.9
<b>50</b>	1   P frigorifique	(Watt)		5169	6966	8957	11189	13710	16569	19814	23492
	2   P absorbée	(W)		4118	4867	5558	6206	6828	7439	8056	8694
	3   I absorbée	(A)		7.86	8.63	9.42	10.2	11.1	12.0	12.9	13.8
<b>60</b>	1   P frigorifique	(Watt)			4920	6557	8341	10323	12549	15069	17929
	2   P absorbée	(W)			4771	5631	6429	7181	7901	8607	9314
	3   I absorbée	(A)			8.73	9.65	10.6	11.6	12.6	13.6	14.7

**60 Hz R404A**

**N°227MU-T**

4   T condensation	5   T évaporation	(°C)	-25	-20	-15	-10	-5	0	5	10	15
<b>30</b>	1   P frigorifique	(Watt)	7739	10013	12607	15580	18990	22897	27360	32438	38189
	2   P absorbée	(W)	4335	4964	5575	6193	6843	7549	8335	9227	10250
	3   I absorbée	(A)	6.89	7.62	8.38	9.17	9.99	10.8	11.7	12.6	13.6
<b>40</b>	1   P frigorifique	(Watt)	6091	8245	10625	13290	16299	19712	23586	27981	32957
	2   P absorbée	(W)	4341	5130	5869	6581	7293	8028	8810	9666	10618
	3   I absorbée	(A)	6.94	7.79	8.68	9.59	10.5	11.5	12.5	13.5	14.6
<b>50</b>	1   P frigorifique	(Watt)		6315	8435	10747	13308	16180	19419	23086	27239
	2   P absorbée	(W)		5073	6004	6876	7714	8542	9386	10268	11215
	3   I absorbée	(A)		7.89	8.90	9.94	11.0	12.1	13.2	14.4	15.6
<b>60</b>	1   P frigorifique	(Watt)			6126	8037	10105	12388	14947	17838	21123
	2   P absorbée	(W)			5864	6960	7989	8975	9943	10918	11923
	3   I absorbée	(A)			9.05	10.2	11.4	12.6	13.9	15.2	16.5

1 = cooling capacity 2 = power input 3 = current 4 = condensing temperature 5 = evaporating temperature

**Nota : Tecumseh se réserve le droit de modifier les informations contenues dans ce document sans préavis.**

**Note : Tecumseh reserves the right to change information contained in this document without notification.**



**Tecumseh**

<b>TAG4581Z</b>	<b>Tension TZ : 400V 3~ 50Hz / 440V 3~ 60 Hz</b>
-----------------	--

Les performances sont données dans les <b>conditions EN12900_HP</b> :	Gaz aspirés :	20.0 °C
Condition Dew	Sous refroidissement :	0.0 K
The performance data are in <b>EN12900_HP conditions</b> :	Return gas :	20.0 °C
Dew Condition	Subcooling :	0.0 K

<b>50 Hz R448A (*)</b>											
											<b>N°2881</b>
4   T condensation	5   T évaporation	(°C)	-25	-20	-15	-10	-5	0	5	10	15
<b>30</b>	1   P frigorifique	(Watt)	5403	7284	9507	12128	15204	18792	22949	27731	33196
	2   P absorbée	(W)	3145	3597	4031	4458	4891	5341	5820	6341	6916
	3   I absorbée	(A)	6.30	6.75	7.24	7.78	8.34	8.95	9.57	10.2	10.9
<b>40</b>	1   P frigorifique	(Watt)		5928	7950	10293	13015	16172	19822	24021	28826
	2   P absorbée	(W)		3708	4253	4773	5281	5788	6307	6849	7427
	3   I absorbée	(A)		6.91	7.51	8.15	8.84	9.55	10.3	11.1	11.8
<b>50</b>	1   P frigorifique	(Watt)			6317	8384	10753	13482	16626	20244	24391
	2   P absorbée	(W)			4339	4998	5626	6236	6840	7450	8077
	3   I absorbée	(A)			7.69	8.47	9.29	10.1	11.0	11.9	12.9
<b>60</b>	1   P frigorifique	(Watt)				6444	8462	10763	13404	16441	19932
	2   P absorbée	(W)				5055	5851	6610	7344	8067	8789
	3   I absorbée	(A)				8.67	9.64	10.7	11.7	12.8	13.9

<b>60 Hz R448A (*)</b>											
											<b>N°2881</b>
4   T condensation	5   T évaporation	(°C)	-25	-20	-15	-10	-5	0	5	10	15
<b>30</b>	1   P frigorifique	(Watt)	6393	8579	11102	14029	17427	21364	25906	31122	37078
	2   P absorbée	(W)	3816	4378	4939	5518	6135	6811	7564	8416	9385
	3   I absorbée	(A)	6.06	6.72	7.42	8.17	8.96	9.78	10.6	11.5	12.4
<b>40</b>	1   P frigorifique	(Watt)		7104	9457	12140	15220	18763	22838	27512	32852
	2   P absorbée	(W)		4545	5223	5889	6564	7267	8017	8836	9743
	3   I absorbée	(A)		6.90	7.72	8.58	9.48	10.4	11.4	12.4	13.4
<b>50</b>	1   P frigorifique	(Watt)			7651	10059	12790	15910	19487	23588	28281
	2   P absorbée	(W)			5352	6184	6995	7803	8630	9495	10418
	3   I absorbée	(A)			7.94	8.94	9.98	11.1	12.2	13.3	14.5
<b>60</b>	1   P frigorifique	(Watt)				7899	10250	12917	15966	19464	23480
	2   P absorbée	(W)				6244	7269	8262	9243	10233	11251
	3   I absorbée	(A)				9.17	10.4	11.6	12.9	14.2	15.6

1 = cooling capacity 2 = power input 3 = current 4 = condensing temperature 5 = evaporating temperature

(\*) Veuillez vous référer strictement aux Recommandations d'Utilisation et Bulletins Marketing Tecumseh du fait de la température de reflux élevée pour les applications LBP.  
 (\*) Due to very high discharge temperature especially on LBP conditions, please strictly refer to Tecumseh Guidelines & Marketing Bulletin when using this refrigerant.

**Nota : Tecumseh se réserve le droit de modifier les informations contenues dans ce document sans préavis.**  
**Note : Tecumseh reserves the right to change information contained in this document without notification.**

© 2021 Tecumseh Products Company  
All rights reserved



**Tecumseh**

<b>TAG4581Z</b>	<b>Tension TZ : 400V 3~ 50Hz / 440V 3~ 60 Hz</b>
-----------------	--

Les performances sont données dans les <b>conditions EN12900_HP</b> :	Gaz aspirés :	20.0 °C
Condition Dew	Sous refroidissement :	0.0 K
The performance data are in <b>EN12900_HP conditions</b> :	Return gas :	20.0 °C
Dew Condition	Subcooling :	0.0 K

© 2021 Tecumseh Products Company  
All rights reserved

### 50 Hz R449A (\*)

**N°2274**

4   T condensation	5   T évaporation	(°C)	-25	-20	-15	-10	-5	0	5	10	15
<b>30</b>	1   P frigorifique	(Watt)	5403	7284	9507	12128	15204	18792	22949	27731	33196
	2   P absorbée	(W)	3145	3597	4031	4458	4891	5341	5820	6341	6916
	3   I absorbée	(A)	6.30	6.75	7.24	7.78	8.34	8.95	9.57	10.2	10.9
<b>40</b>	1   P frigorifique	(Watt)		5928	7950	10293	13015	16172	19822	24021	28826
	2   P absorbée	(W)		3708	4253	4773	5281	5788	6307	6849	7427
	3   I absorbée	(A)		6.91	7.51	8.15	8.84	9.55	10.3	11.1	11.8
<b>50</b>	1   P frigorifique	(Watt)			6317	8384	10753	13482	16626	20244	24391
	2   P absorbée	(W)			4339	4998	5626	6236	6840	7450	8077
	3   I absorbée	(A)			7.69	8.47	9.29	10.1	11.0	11.9	12.9
<b>60</b>	1   P frigorifique	(Watt)				6444	8462	10763	13404	16441	19932
	2   P absorbée	(W)				5055	5851	6610	7344	8067	8789
	3   I absorbée	(A)				8.67	9.64	10.7	11.7	12.8	13.9

### 60 Hz R449A (\*)

**N°2274**

4   T condensation	5   T évaporation	(°C)	-25	-20	-15	-10	-5	0	5	10	15
<b>30</b>	1   P frigorifique	(Watt)	6393	8579	11102	14029	17427	21364	25906	31122	37078
	2   P absorbée	(W)	3816	4378	4939	5518	6135	6811	7564	8416	9385
	3   I absorbée	(A)	6.06	6.72	7.42	8.17	8.96	9.78	10.6	11.5	12.4
<b>40</b>	1   P frigorifique	(Watt)		7104	9457	12140	15220	18763	22838	27512	32852
	2   P absorbée	(W)		4545	5223	5889	6564	7267	8017	8836	9743
	3   I absorbée	(A)		6.90	7.72	8.58	9.48	10.4	11.4	12.4	13.4
<b>50</b>	1   P frigorifique	(Watt)			7651	10059	12790	15910	19487	23588	28281
	2   P absorbée	(W)			5352	6184	6995	7803	8630	9495	10418
	3   I absorbée	(A)			7.94	8.94	9.98	11.1	12.2	13.3	14.5
<b>60</b>	1   P frigorifique	(Watt)				7899	10250	12917	15966	19464	23480
	2   P absorbée	(W)				6244	7269	8262	9243	10233	11251
	3   I absorbée	(A)				9.17	10.4	11.6	12.9	14.2	15.6

1 = cooling capacity 2 = power input 3 = current 4 = condensing temperature 5 = evaporating temperature

(\*) Veuillez vous référer strictement aux Recommandations d'Utilisation et Bulletins Marketing Tecumseh du fait de la température de reflux élevée pour les applications LBP.

(\*) Due to very high discharge temperature especially on LBP conditions, please strictly refer to Tecumseh Guidelines & Marketing Bulletin when using this refrigerant.

**Nota : Tecumseh se réserve le droit de modifier les informations contenues dans ce document sans préavis.**

**Note : Tecumseh reserves the right to change information contained in this document without notification.**