



Compressor
Voltage Code : FZ

AE4430Y-FZ1A

High Temp. Commercial (HP)

220 - 240V 1~ 50 Hz

R134a / R513A

AE4430Y-FZ1A

Conditions	Frequency	Nominal Cooling Capacity		Sound Power ISO3745 / ISO 3743-1
		Watts	BTU/h	
EN12900_HP / R134a	50 Hz	702	2395	52 dBA
EN12900_HP / R513A	50 Hz	714	2436	52 dBA

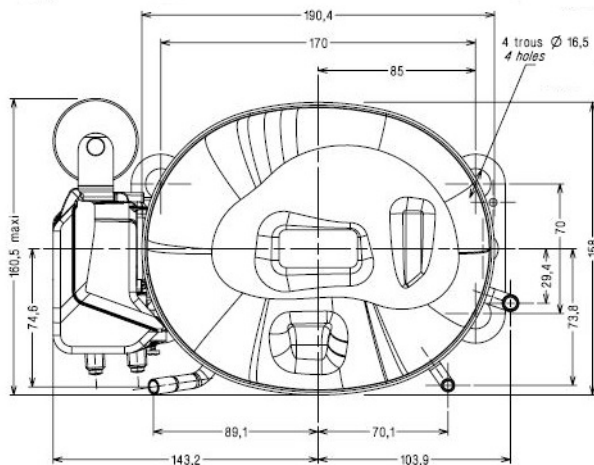
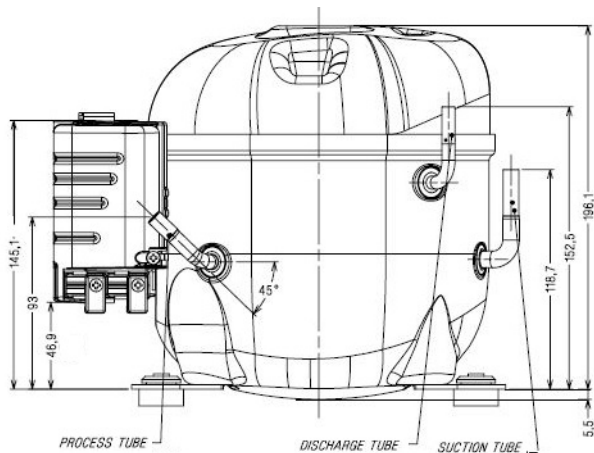

* EN12900_HP : T°Cond. 50.0°C / T°Evap. 5.0°C / T°Return gas temp.. 20.0°C
T°Subcooling. 0.0K

Certificates :



Displacement (cc)	8
Net Weight (Kg)	9.7
Oil Quantity (cc)	285.0
Oil Type	Polyolester
Expansion Device	Capillary_Tube/Expansion_Valve
Cooling	Fan
Main Winding (Ohm)	8.5
Start Winding (Ohm)	53.4
Current	
RLA (A)	2.1
LRA (A)	11.5
Electrical Equipment	CSIR
Overload	MST59AMK
Time Check	7.5s - 14s / 8.5 A
Open Temp	105° C
Close Temp	61° C
Start Capacitor	50 µF / 250 V
Current Relay	MTRP0026
Pick Up	5.4A
Drop Out	4.55A
Refrigerating connection for OD	
Suction Tube	6.35 (1/4")
Discharge Tube	4.76 (3/16")
Process Tube	6.35 (1/4")

Note : Tecumseh reserves the right to change information contained in this document without notification.



Tecumseh

AE4430Y-FZ1A	Tension FZ : 220 - 240V 1~ 50 Hz
---------------------	---

Les performances sont données dans les conditions EN12900_HP :	Gaz aspirés :	20.0 °C
Condition Dew	Sous refroidissement :	0.0 K
The performance data are in EN12900_HP conditions :	Return gas :	20.0 °C
Dew Condition	Subcooling :	0.0 K

50 Hz R134a											
											N°3042
4 T condensation	5 T évaporation	(°C)	-25	-20	-15	-10	-5	0	5	10	15
30	1 P frigorifique	(Watt)	206	277	365	472	599	750	925	1129	1362
	2 P absorbée	(W)	169	184	199	212	224	233	240	243	242
	3 I absorbée	(A)	1.72	1.74	1.76	1.79	1.81	1.83	1.86	1.88	1.90
40	1 P frigorifique	(Watt)	175	239	318	412	526	659	816	998	1207
	2 P absorbée	(W)	175	193	211	230	248	264	278	290	299
	3 I absorbée	(A)	1.70	1.74	1.79	1.83	1.87	1.91	1.96	2.00	2.05
50	1 P frigorifique	(Watt)		201	270	352	450	566	702	861	1045
	2 P absorbée	(W)		199	222	244	267	290	312	332	350
	3 I absorbée	(A)		1.74	1.80	1.86	1.93	1.99	2.05	2.12	2.18
60	1 P frigorifique	(Watt)			223	292	374	471	586	722	879
	2 P absorbée	(W)			231	257	285	313	342	369	396
	3 I absorbée	(A)			1.81	1.89	1.97	2.06	2.14	2.23	2.31

50 Hz R513A											
											N°3169
4 T condensation	5 T évaporation	(°C)	-25	-20	-15	-10	-5	0	5	10	15
30	1 P frigorifique	(Watt)	238	314	405	512	638	784	950	1140	1354
	2 P absorbée	(W)	188	202	215	227	238	249	258	266	273
	3 I absorbée	(A)	1.91	1.91	1.91	1.91	1.93	1.95	2.00	2.06	2.15
40	1 P frigorifique	(Watt)	197	265	346	443	556	688	839	1011	1207
	2 P absorbée	(W)	191	209	227	245	262	278	294	310	324
	3 I absorbée	(A)	1.87	1.90	1.92	1.95	1.98	2.02	2.07	2.14	2.22
50	1 P frigorifique	(Watt)		219	288	370	468	582	714	867	1041
	2 P absorbée	(W)		213	236	259	282	304	327	349	371
	3 I absorbée	(A)		1.86	1.92	1.97	2.03	2.09	2.15	2.23	2.32
60	1 P frigorifique	(Watt)			235	300	379	473	584	713	862
	2 P absorbée	(W)			243	270	299	328	357	386	416
	3 I absorbée	(A)			1.90	1.99	2.07	2.15	2.24	2.33	2.43

1 = cooling capacity 2 = power input 3 = current 4 = condensing temperature 5 = evaporating temperature

Nota : Tecumseh se réserve le droit de modifier les informations contenues dans ce document sans préavis.

Note : Tecumseh reserves the right to change information contained in this document without notification.

© 2021 Tecumseh Products Company
All rights reserved