



Compressor  
Voltage Code : FZ

# AE4440Z-FZ1A

High Temp. Commercial (HP)

220 - 240V 1~ 50 Hz

R452A / R404A / R448A / R449A

AE4440Z-FZ1A

Conditions	Frequency	Nominal Cooling Capacity		Sound Power ISO3745 / ISO 3743-1
		Watts	BTU/h	
EN12900_HP / R452A	50 Hz	895	3051	57 dBA
EN12900_HP / R404A	50 Hz	892	3043	57 dBA
EN12900_HP / R448A	50 Hz	896	3054	57 dBA
EN12900_HP / R449A	50 Hz	896	3054	57 dBA

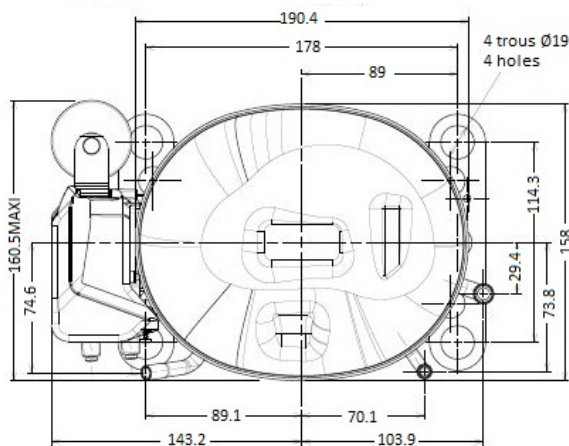
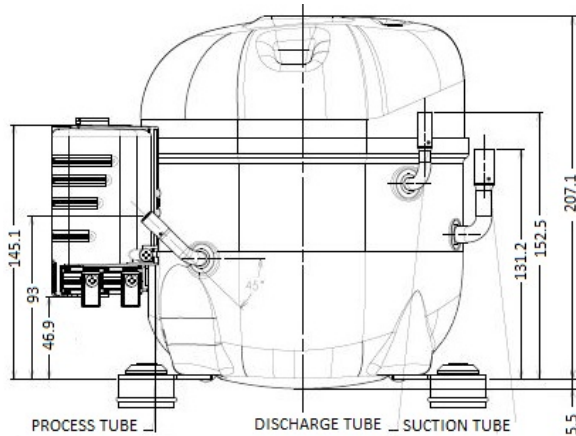

\* EN12900\_HP : T°Cond. 50.0°C / T°Evap. 5.0°C / T°Return gas temp.. 20.0°C  
T°Subcooling. 0.0K

Certificates :



<b>Displacement (cc)</b>	6,69
<b>Net Weight (Kg)</b>	10.2
<b>Oil Quantity (cc)</b>	280.0
<b>Oil Type</b>	Polyolester
<b>Expansion Device</b>	Capillary_Tube/Expansion_Valve
<b>Cooling</b>	Fan
<b>Main Winding (Ohm)</b>	6.79
<b>Start Winding (Ohm)</b>	18.0
<b>Current</b>	
RLA (A)	2.7
LRA (A)	16.0
<b>Electrical Equipment</b>	CSIR
<b>Overload</b>	T1411
Time Check	6.5s - 16s / 10.00 A
Open Temp	140° C
Close Temp	52° C
<b>Start Capacitor</b>	108 µF / 330 V
<b>Current Relay</b>	RP45**
Pick Up	6.75A
Drop Out	5.7A
<b>Refrigerating connection for OD</b>	
Suction Tube	9.5 (3/8")
Discharge Tube	6.35 (1/4")
Process Tube	6.35 (1/4")

Note : Tecumseh reserves the right to change information contained in this document without notification.



**Tecumseh**

<b>AE4440Z-FZ1A</b>	<b>Tension FZ : 220 - 240V 1~ 50 Hz</b>
---------------------	---

Les performances sont données dans les <b>conditions EN12900_HP</b> :	Gaz aspirés :	20.0 °C
Condition Dew	Sous refroidissement :	0.0 K
The performance data are in <b>EN12900_HP conditions</b> :	Return gas :	20.0 °C
Dew Condition	Subcooling :	0.0 K

© 2021 Tecumseh Products Company  
All rights reserved

### 50 Hz R452A

**N°3068**

4   T condensation	5   T évaporation	(°C)	-25	-20	-15	-10	-5	0	5	10	15
<b>30</b>	1   P frigorifique	(Watt)	331	430	550	693	862	1060	1290	1556	1859
	2   P absorbée	(W)	227	249	267	284	296	305	309	308	302
	3   I absorbée	(A)	1.99	2.05	2.10	2.15	2.18	2.21	2.23	2.24	2.24
<b>40</b>	1   P frigorifique	(Watt)		356	462	586	731	900	1096	1322	1581
	2   P absorbée	(W)		263	288	312	332	350	363	372	376
	3   I absorbée	(A)		2.05	2.14	2.21	2.28	2.34	2.39	2.44	2.47
<b>50</b>	1   P frigorifique	(Watt)			369	474	594	733	895	1081	1296
	2   P absorbée	(W)			306	336	365	391	413	432	446
	3   I absorbée	(A)			2.16	2.28	2.38	2.47	2.56	2.63	2.70
<b>60</b>	1   P frigorifique	(Watt)				356	451	561	687	833	1003
	2   P absorbée	(W)				358	395	429	461	490	515
	3   I absorbée	(A)				2.33	2.47	2.60	2.72	2.83	2.93

### 50 Hz R404A

**N°3067**

4   T condensation	5   T évaporation	(°C)	-25	-20	-15	-10	-5	0	5	10	15
<b>30</b>	1   P frigorifique	(Watt)	352	454	575	718	887	1084	1313	1575	1873
	2   P absorbée	(W)	241	262	281	297	309	317	321	318	310
	3   I absorbée	(A)	2.11	2.16	2.21	2.25	2.28	2.30	2.31	2.31	2.30
<b>40</b>	1   P frigorifique	(Watt)	284	375	481	604	747	914	1105	1326	1577
	2   P absorbée	(W)	251	278	304	327	347	364	376	384	386
	3   I absorbée	(A)	2.08	2.17	2.25	2.32	2.38	2.44	2.48	2.51	2.54
<b>50</b>	1   P frigorifique	(Watt)		293	383	486	603	737	892	1071	1275
	2   P absorbée	(W)		292	324	354	382	407	428	445	458
	3   I absorbée	(A)		2.18	2.29	2.40	2.49	2.57	2.65	2.71	2.77
<b>60</b>	1   P frigorifique	(Watt)			282	363	454	557	675	810	967
	2   P absorbée	(W)			342	379	415	448	478	505	527
	3   I absorbée	(A)			2.34	2.47	2.59	2.71	2.82	2.91	3.00

1 = cooling capacity 2 = power input 3 = current 4 = condensing temperature 5 = evaporating temperature

**Nota : Tecumseh se réserve le droit de modifier les informations contenues dans ce document sans préavis.**

**Note : Tecumseh reserves the right to change information contained in this document without notification.**



**Tecumseh**

<b>AE4440Z-FZ1A</b>	<b>Tension FZ : 220 - 240V 1~ 50 Hz</b>
---------------------	---

Les performances sont données dans les <b>conditions EN12900_HP</b> :	Gaz aspirés :	20.0 °C
Condition Dew	Sous refroidissement :	0.0 K
The performance data are in <b>EN12900_HP conditions</b> :	Return gas :	20.0 °C
Dew Condition	Subcooling :	0.0 K

<b>50 Hz R448A (*)</b>											
											<b>N°3069</b>
4   T condensation	5   T évaporation	(°C)	-25	-20	-15	-10	-5	0	5	10	15
<b>30</b>	1   P frigorifique	(Watt)	291	389	506	647	814	1012	1243	1511	1819
	2   P absorbée	(W)	212	231	249	265	278	287	291	290	283
	3   I absorbée	(A)	1.85	1.91	1.96	2.01	2.04	2.08	2.10	2.11	2.11
<b>40</b>	1   P frigorifique	(Watt)		323	428	552	698	870	1070	1303	1572
	2   P absorbée	(W)		247	270	293	313	329	342	351	354
	3   I absorbée	(A)		1.92	2.00	2.08	2.15	2.21	2.26	2.30	2.33
<b>50</b>	1   P frigorifique	(Watt)			348	455	579	725	896	1094	1324
	2   P absorbée	(W)			289	318	346	371	394	412	425
	3   I absorbée	(A)			2.05	2.15	2.26	2.35	2.43	2.51	2.57
<b>60</b>	1   P frigorifique	(Watt)				357	460	580	721	884	1075
	2   P absorbée	(W)				341	377	412	444	473	498
	3   I absorbée	(A)				2.22	2.36	2.49	2.62	2.73	2.83

<b>50 Hz R449A (*)</b>											
											<b>N°3070</b>
4   T condensation	5   T évaporation	(°C)	-25	-20	-15	-10	-5	0	5	10	15
<b>30</b>	1   P frigorifique	(Watt)	291	389	506	647	814	1012	1243	1511	1819
	2   P absorbée	(W)	212	231	249	265	278	287	291	290	283
	3   I absorbée	(A)	1.85	1.91	1.96	2.01	2.04	2.08	2.10	2.11	2.11
<b>40</b>	1   P frigorifique	(Watt)		323	428	552	698	870	1070	1303	1572
	2   P absorbée	(W)		247	270	293	313	329	342	351	354
	3   I absorbée	(A)		1.92	2.00	2.08	2.15	2.21	2.26	2.30	2.33
<b>50</b>	1   P frigorifique	(Watt)			348	455	579	725	896	1094	1324
	2   P absorbée	(W)			289	318	346	371	394	412	425
	3   I absorbée	(A)			2.05	2.15	2.26	2.35	2.43	2.51	2.57
<b>60</b>	1   P frigorifique	(Watt)				357	460	580	721	884	1075
	2   P absorbée	(W)				341	377	412	444	473	498
	3   I absorbée	(A)				2.22	2.36	2.49	2.62	2.73	2.83

**1 = cooling capacity 2 = power input 3 = current 4 = condensing temperature 5 = evaporating temperature**

(\*) Veuillez vous référer strictement aux Recommandations d'Utilisation et Bulletins Marketing Tecumseh du fait de la température de reflux élevée pour les applications LBP.  
 (\*) Due to very high discharge temperature especially on LBP conditions, please strictly refer to Tecumseh Guidelines & Marketing Bulletin when using this refrigerant.

**Nota : Tecumseh se réserve le droit de modifier les informations contenues dans ce document sans préavis.**

**Note : Tecumseh reserves the right to change information contained in this document without notification.**

© 2021 Tecumseh Products Company  
All rights reserved