



Compressor
Voltage Code : TZ

TAJ4519Z-TZ

High Temp. Commercial (HP)

400V 3~ 50Hz / 440V 3~ 60 Hz

R452A / R404A / R448A / R449A

AJ4519Z-TZ1C

Conditions	Frequency	Nominal Cooling Capacity		Sound Power ISO3745 / ISO 3743-1
		Watts	BTU/h	
EN12900_HP / R452A	50 Hz / 60 Hz	4257 / 4768	14516 / 16258	68 dBA
EN12900_HP / R404A	50 Hz / 60 Hz	4246 / 4756	14480 / 16218	68 dBA
EN12900_HP / R448A	50 Hz / 60 Hz	4261 / 4772	14529 / 16273	68 dBA
EN12900_HP / R449A	50 Hz / 60 Hz	4261 / 4772	14529 / 16273	68 dBA

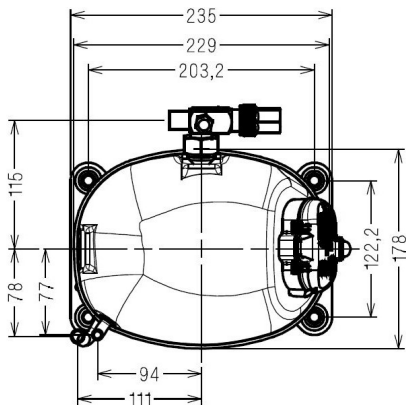
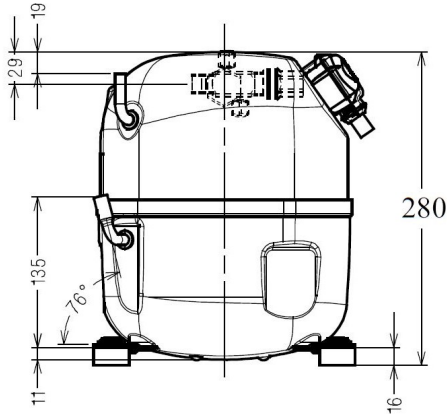

Displacement (cc)	34,45
Net Weight (Kg)	21.1
Oil Quantity (cc)	475.0
Oil Type	Polyolester
Expansion Device	Capillary_Tube/Expansion_Valve
Cooling	Fan
Main Winding (Ohm)	8.7
Current	
RLA (A)	4 4
MCC (A)	6.2 6.3
LRA (A)	22 23
Electrical Equipment	TRI
Overload	Interne
Refrigerating connection for OD	
Suction Tube	15.9 (5/8")
Discharge Tube	9.5 (3/8")
Process Tube	6.35 (1/4")

* EN12900_HP : T°Cond. 50.0°C / T°Evap. 5.0°C / T°Return gas temp.. 20.0°C
T°Subcooling. 0.0K

Certificates :



Note : Tecumseh reserves the right to change information contained in this document without notification.



Tecumseh

TAJ4519Z-TZ	Tension TZ : 400V 3~ 50Hz / 440V 3~ 60 Hz
--------------------	--

Les performances sont données dans les conditions EN12900_HP :	Gaz aspirés :	20.0 °C
Condition Dew	Sous refroidissement :	0.0 K
The performance data are in EN12900_HP conditions :	Return gas :	20.0 °C
Dew Condition	Subcooling :	0.0 K

© 2021 Tecumseh Products Company
All rights reserved

50 Hz R452A

N°2289

4 T condensation	5 T évaporation	(°C)	-25	-20	-15	-10	-5	0	5	10	15
30	1 P frigorifique	(Watt)	1654	2151	2731	3407	4190	5093	6129	7310	8648
	2 P absorbée	(W)	947	1064	1177	1288	1397	1504	1609	1713	1816
	3 I absorbée	(A)	2.59	2.71	2.83	2.96	3.09	3.23	3.37	3.52	3.67
40	1 P frigorifique	(Watt)		1755	2275	2868	3545	4319	5203	6208	7348
	2 P absorbée	(W)		1131	1266	1396	1524	1648	1770	1889	2007
	3 I absorbée	(A)		2.72	2.89	3.06	3.24	3.43	3.62	3.81	4.01
50	1 P frigorifique	(Watt)			1796	2307	2879	3525	4257	5087	6029
	2 P absorbée	(W)			1333	1496	1655	1809	1960	2108	2252
	3 I absorbée	(A)			2.98	3.20	3.43	3.67	3.91	4.15	4.40
60	1 P frigorifique	(Watt)				1716	2184	2702	3284	3941	4685
	2 P absorbée	(W)				1563	1766	1963	2156	2344	2528
	3 I absorbée	(A)				3.38	3.66	3.94	4.23	4.53	4.83

60 Hz R452A

N°2289

4 T condensation	5 T évaporation	(°C)	-25	-20	-15	-10	-5	0	5	10	15
30	1 P frigorifique	(Watt)	1902	2483	3131	3865	4702	5661	6760	8018	9451
	2 P absorbée	(W)	1127	1294	1438	1568	1692	1819	1958	2117	2306
	3 I absorbée	(A)	2.37	2.57	2.77	2.98	3.20	3.43	3.66	3.90	4.15
40	1 P frigorifique	(Watt)		1995	2600	3264	4005	4842	5792	6873	8105
	2 P absorbée	(W)		1317	1514	1688	1847	2001	2158	2327	2516
	3 I absorbée	(A)		2.55	2.79	3.03	3.28	3.54	3.81	4.08	4.36
50	1 P frigorifique	(Watt)			2031	2621	3261	3971	4768	5670	6695
	2 P absorbée	(W)			1549	1775	1978	2167	2351	2538	2737
	3 I absorbée	(A)			2.82	3.10	3.38	3.68	3.97	4.28	4.60
60	1 P frigorifique	(Watt)				1942	2478	3057	3696	4413	5228
	2 P absorbée	(W)				1829	2085	2318	2537	2751	2968
	3 I absorbée	(A)				3.18	3.50	3.83	4.16	4.51	4.86

1 = cooling capacity 2 = power input 3 = current 4 = condensing temperature 5 = evaporating temperature

Nota : Tecumseh se réserve le droit de modifier les informations contenues dans ce document sans préavis.

Note : Tecumseh reserves the right to change information contained in this document without notification.



Tecumseh

TAJ4519Z-TZ	Tension TZ : 400V 3~ 50Hz / 440V 3~ 60 Hz
--------------------	--

Les performances sont données dans les conditions EN12900_HP :	Gaz aspirés :	20.0 °C
Condition Dew	Sous refroidissement :	0.0 K
The performance data are in EN12900_HP conditions :	Return gas :	20.0 °C
Dew Condition	Subcooling :	0.0 K

50 Hz R404A											
											N°224SU-TZ
4 T condensation	5 T évaporation	(°C)	-25	-20	-15	-10	-5	0	5	10	15
30	1 P frigorifique	(Watt)	1764	2268	2853	3530	4312	5209	6234	7398	8713
	2 P absorbée	(W)	1003	1122	1238	1350	1459	1565	1668	1769	1867
	3 I absorbée	(A)	2.74	2.86	2.98	3.10	3.23	3.36	3.49	3.63	3.77
40	1 P frigorifique	(Watt)	1384	1849	2369	2958	3626	4385	5248	6225	7328
	2 P absorbée	(W)	1058	1199	1334	1466	1592	1715	1834	1949	2061
	3 I absorbée	(A)	2.72	2.88	3.05	3.22	3.39	3.57	3.75	3.93	4.12
50	1 P frigorifique	(Watt)		1406	1864	2366	2922	3545	4246	5038	5931
	2 P absorbée	(W)		1244	1412	1575	1732	1884	2030	2172	2309
	3 I absorbée	(A)		2.94	3.16	3.37	3.59	3.82	4.05	4.28	4.51
60	1 P frigorifique	(Watt)			1333	1749	2195	2683	3225	3833	4518
	2 P absorbée	(W)			1449	1655	1854	2047	2234	2415	2589
	3 I absorbée	(A)			3.31	3.57	3.84	4.11	4.39	4.67	4.95

60 Hz R404A											
											N°224SU-TZ
4 T condensation	5 T évaporation	(°C)	-25	-20	-15	-10	-5	0	5	10	15
30	1 P frigorifique	(Watt)	2028	2618	3271	4005	4839	5790	6876	8114	9522
	2 P absorbée	(W)	1194	1365	1512	1643	1767	1893	2030	2186	2372
	3 I absorbée	(A)	2.51	2.71	2.92	3.13	3.34	3.57	3.80	4.03	4.27
40	1 P frigorifique	(Watt)	1532	2102	2707	3366	4097	4916	5842	6892	8083
	2 P absorbée	(W)	1163	1397	1596	1771	1930	2082	2236	2400	2584
	3 I absorbée	(A)	2.47	2.70	2.94	3.18	3.43	3.68	3.94	4.21	4.48
50	1 P frigorifique	(Watt)		1554	2108	2687	3310	3994	4756	5614	6586
	2 P absorbée	(W)		1380	1641	1868	2071	2256	2435	2615	2806
	3 I absorbée	(A)		2.72	2.99	3.26	3.54	3.83	4.12	4.41	4.71
60	1 P frigorifique	(Watt)			1483	1979	2491	3035	3630	4292	5041
	2 P absorbée	(W)			1647	1935	2189	2417	2629	2833	3039
	3 I absorbée	(A)			3.07	3.37	3.68	3.99	4.31	4.64	4.97

1 = cooling capacity 2 = power input 3 = current 4 = condensing temperature 5 = evaporating temperature

Nota : Tecumseh se réserve le droit de modifier les informations contenues dans ce document sans préavis.

Note : Tecumseh reserves the right to change information contained in this document without notification.

© 2021 Tecumseh Products Company
All rights reserved



Tecumseh

TAJ4519Z-TZ	Tension TZ : 400V 3~ 50Hz / 440V 3~ 60 Hz
--------------------	--

Les performances sont données dans les conditions EN12900_HP :	Gaz aspirés :	20.0 °C
Condition Dew	Sous refroidissement :	0.0 K
The performance data are in EN12900_HP conditions :	Return gas :	20.0 °C
Dew Condition	Subcooling :	0.0 K

50 Hz R448A (*)											
											N°2891
4 T condensation	5 T évaporation	(°C)	-25	-20	-15	-10	-5	0	5	10	15
30	1 P frigorifique	(Watt)	1457	1943	2512	3179	3957	4860	5903	7098	8459
	2 P absorbée	(W)	883	990	1097	1203	1308	1412	1514	1613	1708
	3 I absorbée	(A)	2.41	2.52	2.64	2.77	2.90	3.03	3.17	3.31	3.45
40	1 P frigorifique	(Watt)		1592	2109	2702	3386	4175	5081	6120	7305
	2 P absorbée	(W)		1062	1187	1311	1433	1553	1669	1782	1891
	3 I absorbée	(A)		2.55	2.71	2.88	3.05	3.23	3.41	3.60	3.78
50	1 P frigorifique	(Watt)			1691	2215	2808	3486	4261	5147	6158
	2 P absorbée	(W)			1259	1416	1570	1720	1867	2009	2146
	3 I absorbée	(A)			2.81	3.03	3.26	3.49	3.72	3.96	4.19
60	1 P frigorifique	(Watt)				1719	2226	2797	3444	4182	5024
	2 P absorbée	(W)				1486	1688	1884	2076	2263	2443
	3 I absorbée	(A)				3.21	3.49	3.78	4.08	4.37	4.67

60 Hz R448A (*)											
											N°2891
4 T condensation	5 T évaporation	(°C)	-25	-20	-15	-10	-5	0	5	10	15
30	1 P frigorifique	(Watt)	1675	2243	2880	3606	4441	5403	6511	7785	9244
	2 P absorbée	(W)	1050	1205	1340	1464	1585	1708	1842	1994	2170
	3 I absorbée	(A)	2.21	2.39	2.58	2.79	3.00	3.22	3.45	3.68	3.91
40	1 P frigorifique	(Watt)		1810	2410	3076	3826	4680	5657	6776	8057
	2 P absorbée	(W)		1237	1421	1585	1738	1885	2035	2195	2371
	3 I absorbée	(A)		2.40	2.62	2.85	3.09	3.34	3.59	3.85	4.11
50	1 P frigorifique	(Watt)			1912	2516	3181	3927	4772	5736	6838
	2 P absorbée	(W)			1463	1680	1877	2061	2239	2419	2607
	3 I absorbée	(A)			2.67	2.93	3.21	3.50	3.79	4.08	4.38
60	1 P frigorifique	(Watt)				1946	2526	3163	3875	4684	5606
	2 P absorbée	(W)				1738	1992	2224	2443	2655	2868
	3 I absorbée	(A)				3.03	3.35	3.67	4.01	4.35	4.69

1 = cooling capacity 2 = power input 3 = current 4 = condensing temperature 5 = evaporating temperature

(*) Veuillez vous référer strictement aux Recommandations d'Utilisation et Bulletins Marketing Tecumseh du fait de la température de reflux élevée pour les applications LBP.
 (*) Due to very high discharge temperature especially on LBP conditions, please strictly refer to Tecumseh Guidelines & Marketing Bulletin when using this refrigerant.

Nota : Tecumseh se réserve le droit de modifier les informations contenues dans ce document sans préavis.

Note : Tecumseh reserves the right to change information contained in this document without notification.

© 2021 Tecumseh Products Company
All rights reserved



Tecumseh

TAJ4519Z-TZ	Tension TZ : 400V 3~ 50Hz / 440V 3~ 60 Hz
--------------------	--

Les performances sont données dans les conditions EN12900_HP :	Gaz aspirés :	20.0 °C
Condition Dew	Sous refroidissement :	0.0 K
The performance data are in EN12900_HP conditions :	Return gas :	20.0 °C
Dew Condition	Subcooling :	0.0 K

50 Hz R449A (*)											
											N°2285
4 T condensation	5 T évaporation	(°C)	-25	-20	-15	-10	-5	0	5	10	15
30	1 P frigorifique	(Watt)	1457	1943	2512	3179	3957	4860	5903	7098	8459
	2 P absorbée	(W)	883	990	1097	1203	1308	1412	1514	1613	1708
	3 I absorbée	(A)	2.41	2.52	2.64	2.77	2.90	3.03	3.17	3.31	3.45
40	1 P frigorifique	(Watt)		1592	2109	2702	3386	4175	5081	6120	7305
	2 P absorbée	(W)		1062	1187	1311	1433	1553	1669	1782	1891
	3 I absorbée	(A)		2.55	2.71	2.88	3.05	3.23	3.41	3.60	3.78
50	1 P frigorifique	(Watt)			1691	2215	2808	3486	4261	5147	6158
	2 P absorbée	(W)			1259	1416	1570	1720	1867	2009	2146
	3 I absorbée	(A)			2.81	3.03	3.26	3.49	3.72	3.96	4.19
60	1 P frigorifique	(Watt)				1719	2226	2797	3444	4182	5024
	2 P absorbée	(W)				1486	1688	1884	2076	2263	2443
	3 I absorbée	(A)				3.21	3.49	3.78	4.08	4.37	4.67

60 Hz R449A (*)											
											N°2285
4 T condensation	5 T évaporation	(°C)	-25	-20	-15	-10	-5	0	5	10	15
30	1 P frigorifique	(Watt)	1675	2243	2880	3606	4441	5403	6511	7785	9244
	2 P absorbée	(W)	1050	1205	1340	1464	1585	1708	1842	1994	2170
	3 I absorbée	(A)	2.21	2.39	2.58	2.79	3.00	3.22	3.45	3.68	3.91
40	1 P frigorifique	(Watt)		1810	2410	3076	3826	4680	5657	6776	8057
	2 P absorbée	(W)		1237	1421	1585	1738	1885	2035	2195	2371
	3 I absorbée	(A)		2.40	2.62	2.85	3.09	3.34	3.59	3.85	4.11
50	1 P frigorifique	(Watt)			1912	2516	3181	3927	4772	5736	6838
	2 P absorbée	(W)			1463	1680	1877	2061	2239	2419	2607
	3 I absorbée	(A)			2.67	2.93	3.21	3.50	3.79	4.08	4.38
60	1 P frigorifique	(Watt)				1946	2526	3163	3875	4684	5606
	2 P absorbée	(W)				1738	1992	2224	2443	2655	2868
	3 I absorbée	(A)				3.03	3.35	3.67	4.01	4.35	4.69

1 = cooling capacity 2 = power input 3 = current 4 = condensing temperature 5 = evaporating temperature

(*) Veuillez vous référer strictement aux Recommandations d'Utilisation et Bulletins Marketing Tecumseh du fait de la température de refoulement élevée pour les applications LBP.
 (*) Due to very high discharge temperature especially on LBP conditions, please strictly refer to Tecumseh Guidelines & Marketing Bulletin when using this refrigerant.

Nota : Tecumseh se réserve le droit de modifier les informations contenues dans ce document sans préavis.
Note : Tecumseh reserves the right to change information contained in this document without notification.

© 2021 Tecumseh Products Company
All rights reserved