



Compressor  
Voltage Code : TZ

TAJ2464Z-TZ

Low Temp. Commercial (BP)

400V 3~ 50Hz / 440V 3~ 60 Hz

R452A / R404A / R448A / R449A

AJ2444Z-TZ1C

Conditions	Frequency	Nominal Cooling Capacity		Sound Power ISO3745 / ISO 3743-1
		Watts	BTU/h	
EN12900 / R452A	50 Hz / 60 Hz	754 / 829	2572 / 2827	63 dBA
EN12900 / R404A	50 Hz / 60 Hz	820 / 900	2795 / 3071	63 dBA
EN12900 / R448A	50 Hz / 60 Hz	638 / 701	2174 / 2389	63 dBA
EN12900 / R449A	50 Hz / 60 Hz	638 / 701	2174 / 2389	63 dBA

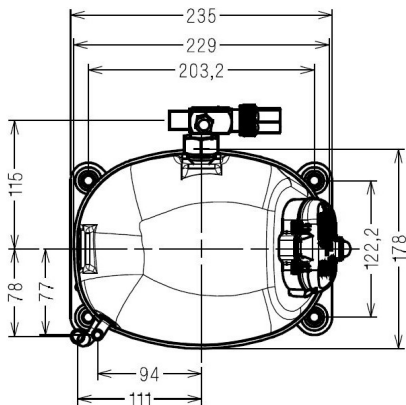
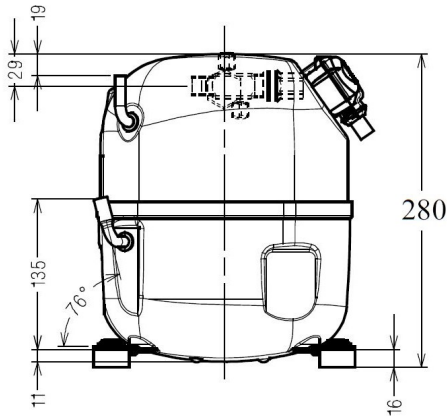

<b>Displacement (cc)</b>	34,5
<b>Net Weight (Kg)</b>	21.2
<b>Oil Quantity (cc)</b>	475.0
<b>Oil Type</b>	Polyolester
<b>Expansion Device</b>	Capillary_Tube/Expansion_Valve
<b>Cooling</b>	Fan
<b>Main Winding (Ohm)</b>	11.8
<b>Current</b>	
RLA (A)	2.2   2.1
MCC (A)	3.8   4
LRA (A)	15.9   16.3
<b>Electrical Equipment</b>	TRI
<b>Overload</b>	Interne
<b>Refrigerating connection for OD</b>	
Suction Tube	15.9 (5/8")
Discharge Tube	9.5 (3/8")
Process Tube	6.35 (1/4")

\* EN12900 : T°Cond. 40.0°C / T°Evap. -35.0°C / T°Return gas temp.. 20.0°C  
T°Subcooling. 0.0K

Certificates :



Note : Tecumseh reserves the right to change information contained in this document without notification.



**Tecumseh**

<b>TAJ2464Z-TZ</b>	<b>Tension TZ : 400V 3~ 50Hz / 440V 3~ 60 Hz</b>
--------------------	--

Les performances sont données dans les <b>conditions EN12900</b> :	Gaz aspirés :	20.0 °C
Condition Dew	Sous refroidissement :	0.0 K
The performance data are in <b>EN12900 conditions</b> :	Return gas :	20.0 °C
Dew Condition	Subcooling :	0.0 K

<b>50 Hz R452A</b>									
<b>N°1092</b>									
4   T condensation	5   T évaporation	(°C)	<b>-40</b>	<b>-35</b>	<b>-30</b>	<b>-25</b>	<b>-20</b>	<b>-15</b>	<b>-10</b>
<b>30</b>	1   P frigorifique	(Watt)	685	947	1267	1651	2108	2646	3272
	2   P absorbée	(W)	607	718	831	948	1070	1198	1334
	3   I absorbée	(A)	1.47	1.58	1.71	1.86	2.03	2.22	2.43
<b>40</b>	1   P frigorifique	(Watt)	524	754	1032	1366	1762	2230	2777
	2   P absorbée	(W)	584	718	854	994	1139	1291	1451
	3   I absorbée	(A)	1.43	1.58	1.75	1.93	2.14	2.36	2.60
<b>50</b>	1   P frigorifique	(Watt)		562	795	1074	1407	1801	2265
	2   P absorbée	(W)		696	856	1021	1191	1368	1553
	3   I absorbée	(A)		1.56	1.76	1.98	2.21	2.47	2.74
<b>60</b>	1   P frigorifique	(Watt)				787	1053	1371	1749
	2   P absorbée	(W)				1029	1225	1429	1642
	3   I absorbée	(A)				2.00	2.26	2.55	2.85

<b>60 Hz R452A</b>									
<b>N°1092</b>									
4   T condensation	5   T évaporation	(°C)	<b>-40</b>	<b>-35</b>	<b>-30</b>	<b>-25</b>	<b>-20</b>	<b>-15</b>	<b>-10</b>
<b>30</b>	1   P frigorifique	(Watt)	752	1041	1394	1819	2325	2921	3615
	2   P absorbée	(W)	697	833	966	1102	1247	1405	1583
	3   I absorbée	(A)	1.37	1.51	1.67	1.86	2.06	2.29	2.55
<b>40</b>	1   P frigorifique	(Watt)	577	829	1135	1504	1943	2462	3069
	2   P absorbée	(W)	668	832	994	1159	1333	1521	1729
	3   I absorbée	(A)	1.33	1.51	1.71	1.93	2.17	2.43	2.72
<b>50</b>	1   P frigorifique	(Watt)		623	879	1187	1556	1995	2512
	2   P absorbée	(W)		793	983	1178	1381	1599	1837
	3   I absorbée	(A)		1.48	1.71	1.97	2.24	2.54	2.85
<b>60</b>	1   P frigorifique	(Watt)				879	1175	1529	1952
	2   P absorbée	(W)				1181	1414	1662	1931
	3   I absorbée	(A)				1.98	2.28	2.61	2.96

1 = cooling capacity 2 = power input 3 = current 4 = condensing temperature 5 = evaporating temperature

**Nota : Tecumseh se réserve le droit de modifier les informations contenues dans ce document sans préavis.**  
**Note : Tecumseh reserves the right to change information contained in this document without notification.**

© 2021 Tecumseh Products Company  
All rights reserved



**Tecumseh**

<b>TAJ2464Z-TZ</b>	<b>Tension TZ : 400V 3~ 50Hz / 440V 3~ 60 Hz</b>
--------------------	--

Les performances sont données dans les <b>conditions EN12900</b> :	Gaz aspirés :	20.0 °C
Condition Dew	Sous refroidissement :	0.0 K
The performance data are in <b>EN12900 conditions</b> :	Return gas :	20.0 °C
Dew Condition	Subcooling :	0.0 K

<b>50 Hz R404A</b>									
<b>N°124SU-TZ</b>									
									
4   T condensation	5   T évaporation	(°C)	-40	-35	-30	-25	-20	-15	-10
<b>30</b>	1   P frigorifique	(Watt)	752	1030	1365	1765	2234	2780	3408
	2   P absorbée	(W)	650	770	892	1015	1141	1270	1405
	3   I absorbée	(A)	1.57	1.69	1.83	1.99	2.16	2.35	2.56
<b>40</b>	1   P frigorifique	(Watt)	578	820	1108	1449	1850	2317	2855
	2   P absorbée	(W)	636	778	920	1066	1215	1369	1529
	3   I absorbée	(A)	1.56	1.71	1.88	2.07	2.28	2.50	2.74
<b>50</b>	1   P frigorifique	(Watt)		612	852	1135	1467	1854	2302
	2   P absorbée	(W)		763	930	1100	1274	1455	1642
	3   I absorbée	(A)		1.71	1.91	2.13	2.37	2.62	2.89
<b>60</b>	1   P frigorifique	(Watt)			601	825	1088	1395	1752
	2   P absorbée	(W)			918	1116	1318	1527	1744
	3   I absorbée	(A)			1.91	2.16	2.43	2.72	3.02

<b>60 Hz R404A</b>									
<b>N°124SU-TZ</b>									
4   T condensation	5   T évaporation	(°C)	-40	-35	-30	-25	-20	-15	-10
<b>30</b>	1   P frigorifique	(Watt)	824	1131	1502	1944	2464	3068	3764
	2   P absorbée	(W)	747	894	1037	1180	1330	1490	1667
	3   I absorbée	(A)	1.46	1.62	1.79	1.99	2.20	2.43	2.68
<b>40</b>	1   P frigorifique	(Watt)	636	900	1218	1596	2040	2558	3156
	2   P absorbée	(W)	728	901	1071	1243	1422	1613	1822
	3   I absorbée	(A)	1.45	1.63	1.84	2.07	2.31	2.58	2.86
<b>50</b>	1   P frigorifique	(Watt)		678	942	1255	1623	2053	2553
	2   P absorbée	(W)		870	1068	1269	1478	1700	1942
	3   I absorbée	(A)		1.62	1.86	2.12	2.40	2.70	3.02
<b>60</b>	1   P frigorifique	(Watt)			675	922	1213	1556	1956
	2   P absorbée	(W)			1050	1281	1521	1776	2051
	3   I absorbée	(A)			1.85	2.14	2.46	2.79	3.14

1 = cooling capacity 2 = power input 3 = current 4 = condensing temperature 5 = evaporating temperature

**Nota : Tecumseh se réserve le droit de modifier les informations contenues dans ce document sans préavis.**

**Note : Tecumseh reserves the right to change information contained in this document without notification.**

© 2021 Tecumseh Products Company  
All rights reserved



**Tecumseh**

<b>TAJ2464Z-TZ</b>	<b>Tension TZ : 400V 3~ 50Hz / 440V 3~ 60 Hz</b>
--------------------	--

Les performances sont données dans les <b>conditions EN12900</b> :	Gaz aspirés :	20.0 °C
Condition Dew	Sous refroidissement :	0.0 K
The performance data are in <b>EN12900 conditions</b> :	Return gas :	20.0 °C
Dew Condition	Subcooling :	0.0 K

<b>50 Hz R448A (*)</b>								
<b>N°2746</b>								
4   T condensation	5   T évaporation	(°C)	<b>-35</b>	<b>-30</b>	<b>-25</b>	<b>-20</b>	<b>-15</b>	<b>-10</b>
<b>30</b>	1   P frigorifique	(Watt)	802	1118	1503	1965	2511	3149
	2   P absorbée	(W)	666	778	893	1011	1136	1267
	3   I absorbée	(A)	1.46	1.60	1.75	1.92	2.10	2.31
<b>40</b>	1   P frigorifique	(Watt)	638	911	1244	1646	2123	2683
	2   P absorbée	(W)	674	807	941	1079	1223	1373
	3   I absorbée	(A)	1.48	1.65	1.83	2.02	2.23	2.46
<b>50</b>	1   P frigorifique	(Watt)	481	713	998	1341	1751	2236
	2   P absorbée	(W)	660	817	976	1138	1304	1477
	3   I absorbée	(A)	1.48	1.68	1.89	2.11	2.35	2.60
<b>60</b>	1   P frigorifique	(Watt)			774	1062	1408	1819
	2   P absorbée	(W)			989	1180	1374	1575
	3   I absorbée	(A)			1.92	2.18	2.45	2.73

<b>60 Hz R448A (*)</b>								
<b>N°2746</b>								
4   T condensation	5   T évaporation	(°C)	<b>-35</b>	<b>-30</b>	<b>-25</b>	<b>-20</b>	<b>-15</b>	<b>-10</b>
<b>30</b>	1   P frigorifique	(Watt)	881	1230	1656	2167	2771	3478
	2   P absorbée	(W)	773	905	1038	1179	1332	1503
	3   I absorbée	(A)	1.40	1.57	1.75	1.95	2.17	2.42
<b>40</b>	1   P frigorifique	(Watt)	701	1001	1370	1815	2343	2965
	2   P absorbée	(W)	782	939	1098	1263	1441	1636
	3   I absorbée	(A)	1.42	1.61	1.83	2.06	2.30	2.57
<b>50</b>	1   P frigorifique	(Watt)	533	788	1102	1483	1939	2479
	2   P absorbée	(W)	752	938	1125	1319	1524	1747
	3   I absorbée	(A)	1.40	1.63	1.88	2.14	2.42	2.71
<b>60</b>	1   P frigorifique	(Watt)			865	1185	1570	2030
	2   P absorbée	(W)			1136	1361	1598	1852
	3   I absorbée	(A)			1.90	2.20	2.51	2.84

**1 = cooling capacity 2 = power input 3 = current 4 = condensing temperature 5 = evaporating temperature**

(\*) Veuillez vous référer strictement aux Recommandations d'Utilisation et Bulletins Marketing Tecumseh du fait de la température de refoulement élevée pour les applications LBP.  
 (\*) Due to very high discharge temperature especially on LBP conditions, please strictly refer to Tecumseh Guidelines & Marketing Bulletin when using this refrigerant.

**Nota : Tecumseh se réserve le droit de modifier les informations contenues dans ce document sans préavis.**

**Note : Tecumseh reserves the right to change information contained in this document without notification.**

© 2021 Tecumseh Products Company  
All rights reserved



**Tecumseh**

<b>TAJ2464Z-TZ</b>	<b>Tension TZ : 400V 3~ 50Hz / 440V 3~ 60 Hz</b>
--------------------	--

Les performances sont données dans les <b>conditions EN12900</b> :	Gaz aspirés :	20.0 °C
Condition Dew	Sous refroidissement :	0.0 K
The performance data are in <b>EN12900 conditions</b> :	Return gas :	20.0 °C
Dew Condition	Subcooling :	0.0 K

© 2021 Tecumseh Products Company  
All rights reserved

### 50 Hz R449A (\*)

**N°2001**

4   T condensation	5   T évaporation	(°C)	-35	-30	-25	-20	-15	-10
<b>30</b>	1   P frigorifique	(Watt)	802	1118	1503	1965	2511	3149
	2   P absorbée	(W)	666	778	893	1011	1136	1267
	3   I absorbée	(A)	1.46	1.60	1.75	1.92	2.10	2.31
<b>40</b>	1   P frigorifique	(Watt)	638	911	1244	1646	2123	2683
	2   P absorbée	(W)	674	807	941	1079	1223	1373
	3   I absorbée	(A)	1.48	1.65	1.83	2.02	2.23	2.46
<b>50</b>	1   P frigorifique	(Watt)	481	713	998	1341	1751	2236
	2   P absorbée	(W)	660	817	976	1138	1304	1477
	3   I absorbée	(A)	1.48	1.68	1.89	2.11	2.35	2.60
<b>60</b>	1   P frigorifique	(Watt)			774	1062	1408	1819
	2   P absorbée	(W)			989	1180	1374	1575
	3   I absorbée	(A)			1.92	2.18	2.45	2.73

### 60 Hz R449A (\*)

**N°2001**

4   T condensation	5   T évaporation	(°C)	-35	-30	-25	-20	-15	-10
<b>30</b>	1   P frigorifique	(Watt)	881	1230	1656	2167	2771	3478
	2   P absorbée	(W)	773	905	1038	1179	1332	1503
	3   I absorbée	(A)	1.40	1.57	1.75	1.95	2.17	2.42
<b>40</b>	1   P frigorifique	(Watt)	701	1001	1370	1815	2343	2965
	2   P absorbée	(W)	782	939	1098	1263	1441	1636
	3   I absorbée	(A)	1.42	1.61	1.83	2.06	2.30	2.57
<b>50</b>	1   P frigorifique	(Watt)	533	788	1102	1483	1939	2479
	2   P absorbée	(W)	752	938	1125	1319	1524	1747
	3   I absorbée	(A)	1.40	1.63	1.88	2.14	2.42	2.71
<b>60</b>	1   P frigorifique	(Watt)			865	1185	1570	2030
	2   P absorbée	(W)			1136	1361	1598	1852
	3   I absorbée	(A)			1.90	2.20	2.51	2.84

1 = cooling capacity 2 = power input 3 = current 4 = condensing temperature 5 = evaporating temperature

(\*) Veuillez vous référer strictement aux Recommandations d'Utilisation et Bulletins Marketing Tecumseh du fait de la température de refoulement élevée pour les applications LBP.

(\*) Due to very high discharge temperature especially on LBP conditions, please strictly refer to Tecumseh Guidelines & Marketing Bulletin when using this refrigerant.

**Nota : Tecumseh se réserve le droit de modifier les informations contenues dans ce document sans préavis.**

**Note : Tecumseh reserves the right to change information contained in this document without notification.**