



Tecumseh

Compressor Voltage Code : XG

FH4522Z-XG

High Temp. Commercial (HP)

380-420V 3~ 50Hz / 460V 3~ 60 Hz

R452A / R404A / R448A / R449A

FH4522Z-XG1A

Conditions	Frequency	Nominal Cooling Capacity		Sound Power ISO3745 / ISO 3743-1
		Watts	BTU/h	
EN12900_HP / R452A	50 Hz / 60 Hz	4745 / 5638	16181 / 19227	73 dBA
EN12900_HP / R404A	50 Hz / 60 Hz	4736 / 5627	16150 / 19188	73 dBA
EN12900_HP / R448A	50 Hz / 60 Hz	4753 / 5649	16206 / 19263	73 dBA
EN12900_HP / R449A	50 Hz / 60 Hz	4753 / 5649	16206 / 19263	73 dBA

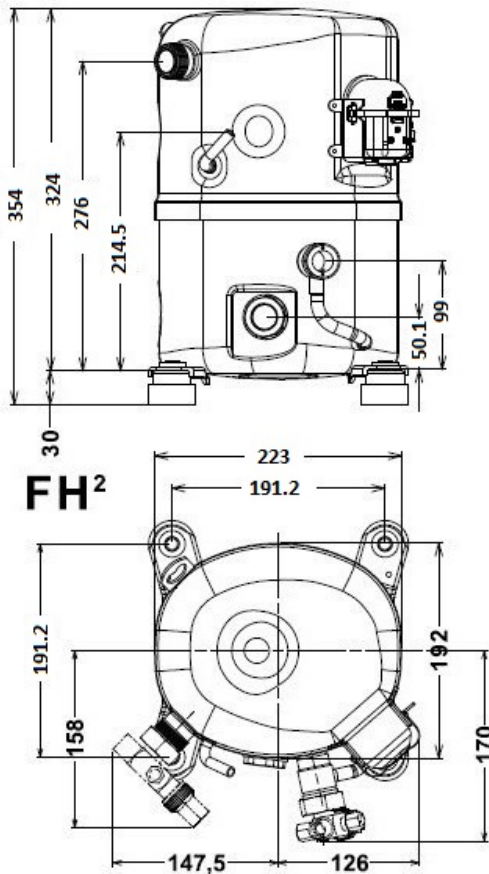

Displacement (cc)	39,6
Net Weight (Kg)	33.0
Oil Quantity (cc)	1140.0
Oil Type	Polyolester
Expansion Device	Capillary_Tube/Expansion_Valve
Cooling	Fan
Main Winding (Ohm)	15.0
Current	
RLA (A)	3.2 3.3
MCC (A)	5.4
LRA (A)	20
Electrical Equipment	TRI
Overload	Interne
Refrigerating connection for OD	
Suction Tube	15.9 (5/8")
Discharge Tube	12.7 (1/2")
Process Tube	6.35 (1/4")

* EN12900_HP : T°Cond. 50.0°C / T°Evap. 5.0°C / T°Return gas temp.. 20.0°C
T°Subcooling. 0.0K

Certificates :



Note : Tecumseh reserves the right to change information contained in this document without notification.



Tecumseh

FH4522Z-XG	Tension XG : 380-420V 3~ 50Hz / 460V 3~ 60 Hz
-------------------	--

Les performances sont données dans les conditions EN12900_HP :	Gaz aspirés :	20.0 °C
Condition Dew	Sous refroidissement :	0.0 K
The performance data are in EN12900_HP conditions :	Return gas :	20.0 °C
Dew Condition	Subcooling :	0.0 K

© 2021 Tecumseh Products Company
All rights reserved

50 Hz R452A

N°User-222

4 T condensation	5 T évaporation	(°C)	-25	-20	-15	-10	-5	0	5	10	15
30	1 P frigorifique	(Watt)	1574	2189	2920	3785	4800	5983	7353	8924	10716
	2 P absorbée	(W)	859	983	1091	1184	1261	1324	1372	1407	1429
	3 I absorbée	(A)	1.70	1.87	2.00	2.12	2.21	2.29	2.34	2.39	2.43
40	1 P frigorifique	(Watt)		1634	2271	3011	3872	4872	6027	7356	8875
	2 P absorbée	(W)		1008	1157	1288	1403	1501	1583	1650	1703
	3 I absorbée	(A)		1.87	2.08	2.26	2.42	2.55	2.67	2.77	2.85
50	1 P frigorifique	(Watt)			1648	2268	2979	3799	4745	5835	7085
	2 P absorbée	(W)			1170	1352	1516	1662	1790	1901	1996
	3 I absorbée	(A)			2.08	2.34	2.57	2.77	2.95	3.11	3.25
60	1 P frigorifique	(Watt)				1562	2127	2771	3512	4367	5352
	2 P absorbée	(W)				1347	1571	1776	1962	2129	2278
	3 I absorbée	(A)				2.34	2.65	2.93	3.18	3.40	3.61

60 Hz R452A

N°User-222

4 T condensation	5 T évaporation	(°C)	-25	-20	-15	-10	-5	0	5	10	15
30	1 P frigorifique	(Watt)	1658	2414	3266	4235	5343	6612	8062	9717	11596
	2 P absorbée	(W)	960	1156	1324	1462	1571	1653	1707	1735	1737
	3 I absorbée	(A)	1.69	1.88	2.05	2.19	2.31	2.40	2.48	2.54	2.60
40	1 P frigorifique	(Watt)		1797	2580	3458	4453	5585	6877	8349	10025
	2 P absorbée	(W)		1124	1350	1546	1712	1849	1957	2038	2091
	3 I absorbée	(A)		1.85	2.08	2.29	2.47	2.62	2.75	2.86	2.95
50	1 P frigorifique	(Watt)			1871	2651	3524	4513	5638	6922	8386
	2 P absorbée	(W)			1321	1577	1802	1997	2162	2298	2406
	3 I absorbée	(A)			2.05	2.33	2.58	2.80	2.99	3.16	3.31
60	1 P frigorifique	(Watt)				1867	2613	3451	4403	5491	6737
	2 P absorbée	(W)				1556	1843	2098	2322	2516	2680
	3 I absorbée	(A)				2.29	2.62	2.91	3.18	3.42	3.63

1 = cooling capacity 2 = power input 3 = current 4 = condensing temperature 5 = evaporating temperature

Nota : Tecumseh se réserve le droit de modifier les informations contenues dans ce document sans préavis.

Note : Tecumseh reserves the right to change information contained in this document without notification.



Tecumseh

FH4522Z-XG	Tension XG : 380-420V 3~ 50Hz / 460V 3~ 60 Hz
-------------------	--

Les performances sont données dans les conditions EN12900_HP :	Gaz aspirés :	20.0 °C
Condition Dew	Sous refroidissement :	0.0 K
The performance data are in EN12900_HP conditions :	Return gas :	20.0 °C
Dew Condition	Subcooling :	0.0 K

© 2021 Tecumseh Products Company
All rights reserved

50 Hz R404A

N°User-221

4 T condensation	5 T évaporation	(°C)	-25	-20	-15	-10	-5	0	5	10	15
30	1 P frigorifique	(Watt)	1696	2309	3040	3907	4924	6108	7476	9043	10826
	2 P absorbée	(W)	920	1046	1156	1248	1322	1376	1411	1425	1418
	3 I absorbée	(A)	1.82	1.99	2.12	2.23	2.32	2.38	2.41	2.42	2.41
40	1 P frigorifique	(Watt)	1201	1744	2373	3106	3957	4944	6083	7389	8879
	2 P absorbée	(W)	912	1076	1223	1354	1468	1563	1639	1694	1729
	3 I absorbée	(A)	1.76	1.99	2.20	2.38	2.53	2.66	2.76	2.84	2.89
50	1 P frigorifique	(Watt)		1197	1730	2334	3026	3821	4736	5787	6989
	2 P absorbée	(W)		1054	1247	1424	1584	1726	1850	1954	2038
	3 I absorbée	(A)		1.95	2.22	2.46	2.69	2.88	3.05	3.20	3.32
60	1 P frigorifique	(Watt)			1117	1599	2136	2746	3442	4243	5165
	2 P absorbée	(W)			1208	1438	1652	1849	2027	2187	2327
	3 I absorbée	(A)			2.19	2.50	2.79	3.05	3.28	3.50	3.68

60 Hz R404A

N°User-221

4 T condensation	5 T évaporation	(°C)	-25	-20	-15	-10	-5	0	5	10	15
30	1 P frigorifique	(Watt)	1787	2545	3400	4372	5481	6750	8198	9846	11715
	2 P absorbée	(W)	1028	1231	1402	1540	1646	1718	1755	1758	1726
	3 I absorbée	(A)	1.81	2.00	2.17	2.31	2.42	2.50	2.55	2.58	2.57
40	1 P frigorifique	(Watt)	1209	1917	2697	3568	4552	5669	6941	8387	10029
	2 P absorbée	(W)	939	1199	1428	1626	1791	1925	2025	2091	2124
	3 I absorbée	(A)	1.71	1.97	2.20	2.41	2.58	2.73	2.84	2.94	3.00
50	1 P frigorifique	(Watt)		1268	1965	2729	3580	4539	5627	6864	8272
	2 P absorbée	(W)		1124	1407	1661	1884	2075	2235	2362	2456
	3 I absorbée	(A)		1.89	2.18	2.45	2.69	2.91	3.09	3.25	3.38
60	1 P frigorifique	(Watt)			1263	1912	2623	3417	4315	5337	6503
	2 P absorbée	(W)			1354	1661	1937	2184	2400	2584	2737
	3 I absorbée	(A)			2.11	2.45	2.75	3.03	3.28	3.51	3.70

1 = cooling capacity 2 = power input 3 = current 4 = condensing temperature 5 = evaporating temperature

Nota : Tecumseh se réserve le droit de modifier les informations contenues dans ce document sans préavis.

Note : Tecumseh reserves the right to change information contained in this document without notification.



Tecumseh

FH4522Z-XG	Tension XG : 380-420V 3~ 50Hz / 460V 3~ 60 Hz
-------------------	--

Les performances sont données dans les conditions EN12900_HP : Condition Dew	Gaz aspirés : 20.0 °C Sous refroidissement : 0.0 K
The performance data are in EN12900_HP conditions : Dew Condition	Return gas : 20.0 °C Subcooling : 0.0 K

© 2021 Tecumseh Products Company
All rights reserved

50 Hz R448A (*)

N°User-224

4 T condensation	5 T évaporation	(°C)	-25	-20	-15	-10	-5	0	5	10	15
30	1 P frigorifique	(Watt)	1402	1978	2677	3517	4518	5699	7078	8676	10511
	2 P absorbée	(W)	810	923	1025	1113	1186	1243	1281	1299	1296
	3 I absorbée	(A)	1.60	1.75	1.88	1.99	2.08	2.15	2.19	2.21	2.20
40	1 P frigorifique	(Watt)		1503	2113	2837	3695	4707	5890	7265	8851
	2 P absorbée	(W)		952	1088	1212	1321	1415	1492	1550	1587
	3 I absorbée	(A)		1.77	1.96	2.13	2.28	2.41	2.51	2.60	2.66
50	1 P frigorifique	(Watt)			1568	2185	2908	3757	4753	5913	7257
	2 P absorbée	(W)			1111	1280	1435	1576	1701	1807	1895
	3 I absorbée	(A)			1.98	2.22	2.43	2.63	2.80	2.96	3.08
60	1 P frigorifique	(Watt)				1572	2168	2863	3678	4630	5740
	2 P absorbée	(W)				1293	1504	1702	1884	2049	2195
	3 I absorbée	(A)				2.25	2.54	2.80	3.05	3.28	3.48

60 Hz R448A (*)

N°User-224

4 T condensation	5 T évaporation	(°C)	-25	-20	-15	-10	-5	0	5	10	15
30	1 P frigorifique	(Watt)	1478	2185	2997	3937	5029	6296	7760	9445	11373
	2 P absorbée	(W)	905	1086	1243	1374	1477	1551	1593	1603	1577
	3 I absorbée	(A)	1.59	1.77	1.92	2.06	2.17	2.26	2.32	2.35	2.35
40	1 P frigorifique	(Watt)		1653	2400	3257	4248	5394	6719	8246	9998
	2 P absorbée	(W)		1062	1270	1454	1613	1743	1844	1913	1949
	3 I absorbée	(A)		1.75	1.96	2.15	2.32	2.47	2.59	2.68	2.75
50	1 P frigorifique	(Watt)			1778	2551	3439	4464	5649	7018	8593
	2 P absorbée	(W)			1254	1493	1707	1895	2055	2185	2283
	3 I absorbée	(A)			1.95	2.21	2.44	2.65	2.84	3.00	3.14
60	1 P frigorifique	(Watt)				1880	2664	3567	4611	5821	7218
	2 P absorbée	(W)				1493	1764	2010	2229	2421	2583
	3 I absorbée	(A)				2.20	2.51	2.79	3.05	3.29	3.50

1 = cooling capacity 2 = power input 3 = current 4 = condensing temperature 5 = evaporating temperature

(*) Veuillez vous référer strictement aux Recommandations d'Utilisation et Bulletins Marketing Tecumseh du fait de la température de refoulement élevée pour les applications LBP.

(*) Due to very high discharge temperature especially on LBP conditions, please strictly refer to Tecumseh Guidelines & Marketing Bulletin when using this refrigerant.

Nota : Tecumseh se réserve le droit de modifier les informations contenues dans ce document sans préavis.

Note : Tecumseh reserves the right to change information contained in this document without notification.



Tecumseh

FH4522Z-XG	Tension XG : 380-420V 3~ 50Hz / 460V 3~ 60 Hz
-------------------	--

Les performances sont données dans les conditions EN12900_HP :	Gaz aspirés :	20.0 °C
Condition Dew	Sous refroidissement :	0.0 K
The performance data are in EN12900_HP conditions :	Return gas :	20.0 °C
Dew Condition	Subcooling :	0.0 K

© 2021 Tecumseh Products Company
All rights reserved

50 Hz R449A (*)

N°User-223

4 T condensation	5 T évaporation	(°C)	-25	-20	-15	-10	-5	0	5	10	15
30	1 P frigorifique	(Watt)	1402	1978	2677	3517	4518	5699	7078	8676	10511
	2 P absorbée	(W)	810	923	1025	1113	1186	1243	1281	1299	1296
	3 I absorbée	(A)	1.60	1.75	1.88	1.99	2.08	2.15	2.19	2.21	2.20
40	1 P frigorifique	(Watt)		1503	2113	2837	3695	4707	5890	7265	8851
	2 P absorbée	(W)		952	1088	1212	1321	1415	1492	1550	1587
	3 I absorbée	(A)		1.77	1.96	2.13	2.28	2.41	2.51	2.60	2.66
50	1 P frigorifique	(Watt)			1568	2185	2908	3757	4753	5913	7257
	2 P absorbée	(W)			1111	1280	1435	1576	1701	1807	1895
	3 I absorbée	(A)			1.98	2.22	2.43	2.63	2.80	2.96	3.08
60	1 P frigorifique	(Watt)				1572	2168	2863	3678	4630	5740
	2 P absorbée	(W)				1293	1504	1702	1884	2049	2195
	3 I absorbée	(A)				2.25	2.54	2.80	3.05	3.28	3.48

60 Hz R449A (*)

N°User-223

4 T condensation	5 T évaporation	(°C)	-25	-20	-15	-10	-5	0	5	10	15
30	1 P frigorifique	(Watt)	1478	2185	2997	3937	5029	6296	7760	9445	11373
	2 P absorbée	(W)	905	1086	1243	1374	1477	1551	1593	1603	1577
	3 I absorbée	(A)	1.59	1.77	1.92	2.06	2.17	2.26	2.32	2.35	2.35
40	1 P frigorifique	(Watt)		1653	2400	3257	4248	5394	6719	8246	9998
	2 P absorbée	(W)		1062	1270	1454	1613	1743	1844	1913	1949
	3 I absorbée	(A)		1.75	1.96	2.15	2.32	2.47	2.59	2.68	2.75
50	1 P frigorifique	(Watt)			1778	2551	3439	4464	5649	7018	8593
	2 P absorbée	(W)			1254	1493	1707	1895	2055	2185	2283
	3 I absorbée	(A)			1.95	2.21	2.44	2.65	2.84	3.00	3.14
60	1 P frigorifique	(Watt)				1880	2664	3567	4611	5821	7218
	2 P absorbée	(W)				1493	1764	2010	2229	2421	2583
	3 I absorbée	(A)				2.20	2.51	2.79	3.05	3.29	3.50

1 = cooling capacity 2 = power input 3 = current 4 = condensing temperature 5 = evaporating temperature

(*) Veuillez vous référer strictement aux Recommandations d'Utilisation et Bulletins Marketing Tecumseh du fait de la température de refoulement élevée pour les applications LBP.

(*) Due to very high discharge temperature especially on LBP conditions, please strictly refer to Tecumseh Guidelines & Marketing Bulletin when using this refrigerant.

Nota : Tecumseh se réserve le droit de modifier les informations contenues dans ce document sans préavis.

Note : Tecumseh reserves the right to change information contained in this document without notification.