



Compressor
Voltage Code : XG

FH4518Y-XG

High Temp. Commercial (HP)

380-420V 3~ 50Hz / 460V 3~ 60 Hz

R134a / R513A

FH4518Y-XG1A

Conditions	Frequency	Nominal Cooling Capacity		Sound Power ISO3745 / ISO 3743-1
		Watts	BTU/h	
EN12900_HP / R134a	50 Hz / 60 Hz	3851 / 4689	13131 / 15989	69 dBA
EN12900_HP / R513A	50 Hz / 60 Hz	3919 / 4771	13363 / 16269	69 dBA

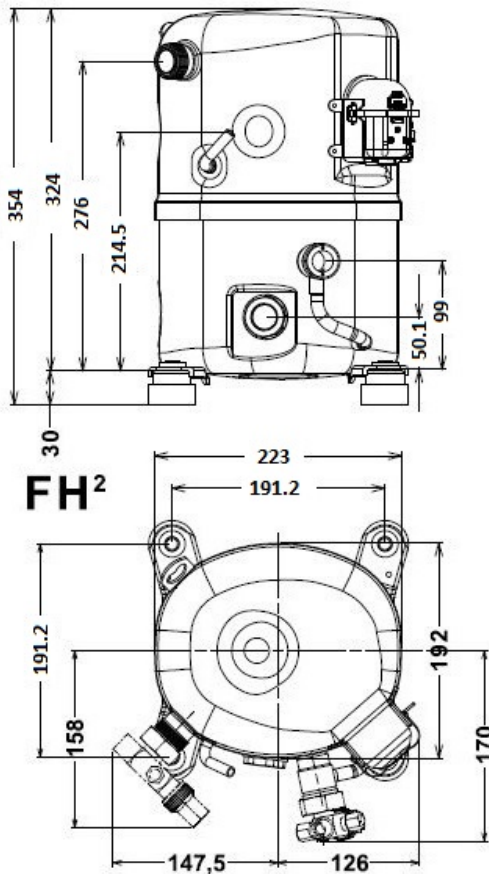

Displacement (cc)	48,5
Net Weight (Kg)	29.0
Oil Quantity (cc)	1140.0
Oil Type	Polyolester
Expansion Device	Capillary_Tube/Expansion_Valve
Cooling	Fan
Main Winding (Ohm)	9.8
Current	
RLA (A)	2.5 2.5
MCC (A)	4.9
LRA (A)	18
Electrical Equipment	TRI
Overload	Interne
Refrigerating connection for OD	
Suction Tube	15.9 (5/8")
Discharge Tube	12.7 (1/2")
Process Tube	6.35 (1/4")

* EN12900_HP : T°Cond. 50.0°C / T°Evap. 5.0°C / T°Return gas temp.. 20.0°C
T°Subcooling. 0.0K

Certificates :



Note : Tecumseh reserves the right to change information contained in this document without notification.



Tecumseh

FH4518Y-XG	Tension XG : 380-420V 3~ 50Hz / 460V 3~ 60 Hz
-------------------	--

Les performances sont données dans les **conditions EN12900_HP** :
 Condition Dew
 The performance data are in **EN12900_HP conditions** :
 Dew Condition

Gaz aspirés : 20.0 °C
 Sous refroidissement : 0.0 K
 Return gas : 20.0 °C
 Subcooling : 0.0 K

© 2021 Tecumseh Products Company
All rights reserved

50 Hz R134a

N°User-357

4 T condensation	5 T évaporation	(°C)	-25	-20	-15	-10	-5	0	5	10	15
30	1 P frigorifique	(Watt)	1041	1498	2054	2725	3526	4475	5586	6876	8360
	2 P absorbée	(W)	582	683	773	853	925	990	1049	1102	1153
	3 I absorbée	(A)	1.13	1.27	1.37	1.46	1.53	1.57	1.59	1.59	1.56
40	1 P frigorifique	(Watt)	758	1165	1648	2222	2904	3709	4654	5754	7024
	2 P absorbée	(W)	551	681	801	912	1016	1115	1208	1298	1385
	3 I absorbée	(A)	1.06	1.28	1.47	1.65	1.80	1.93	2.03	2.12	2.18
50	1 P frigorifique	(Watt)		870	1297	1793	2374	3054	3851	4779	5855
	2 P absorbée	(W)		665	814	955	1090	1220	1347	1471	1594
	3 I absorbée	(A)		1.19	1.47	1.73	1.97	2.18	2.37	2.54	2.69
60	1 P frigorifique	(Watt)			987	1423	1920	2494	3161	3935	4835
	2 P absorbée	(W)			833	1002	1166	1327	1485	1643	1800
	3 I absorbée	(A)			1.36	1.71	2.03	2.33	2.61	2.87	3.10

60 Hz R134a

N°User-357

4 T condensation	5 T évaporation	(°C)	-25	-20	-15	-10	-5	0	5	10	15
30	1 P frigorifique	(Watt)	1234	1815	2494	3288	4215	5293	6538	7968	9601
	2 P absorbée	(W)	715	825	925	1016	1101	1181	1259	1336	1414
	3 I absorbée	(A)	1.08	1.25	1.41	1.56	1.70	1.83	1.95	2.05	2.15
40	1 P frigorifique	(Watt)	836	1377	1997	2711	3539	4497	5603	6875	8329
	2 P absorbée	(W)	691	839	975	1101	1220	1333	1443	1550	1658
	3 I absorbée	(A)	1.01	1.23	1.43	1.63	1.82	2.00	2.16	2.32	2.47
50	1 P frigorifique	(Watt)		962	1521	2156	2884	3722	4689	5800	7075
	2 P absorbée	(W)		805	985	1155	1315	1469	1618	1763	1908
	3 I absorbée	(A)		1.19	1.45	1.70	1.93	2.16	2.37	2.58	2.77
60	1 P frigorifique	(Watt)			1091	1646	2273	2991	3817	4768	5862
	2 P absorbée	(W)			949	1169	1379	1581	1777	1968	2158
	3 I absorbée	(A)			1.45	1.75	2.03	2.31	2.57	2.83	3.07

1 = cooling capacity 2 = power input 3 = current 4 = condensing temperature 5 = evaporating temperature

Nota : Tecumseh se réserve le droit de modifier les informations contenues dans ce document sans préavis.

Note : Tecumseh reserves the right to change information contained in this document without notification.



Tecumseh

FH4518Y-XG	Tension XG : 380-420V 3~ 50Hz / 460V 3~ 60 Hz
-------------------	--

Les performances sont données dans les conditions EN12900_HP :	Gaz aspirés :	20.0 °C
Condition Dew	Sous refroidissement :	0.0 K
The performance data are in EN12900_HP conditions :	Return gas :	20.0 °C
Dew Condition	Subcooling :	0.0 K

50 Hz R513A											
											N°User-358
4 T condensation	5 T évaporation	(°C)	-25	-20	-15	-10	-5	0	5	10	15
30	1 P frigorifique	(Watt)	1199	1694	2278	2962	3758	4678	5735	6940	8306
	2 P absorbée	(W)	647	749	836	914	985	1055	1128	1208	1299
	3 I absorbée	(A)	1.26	1.39	1.49	1.57	1.63	1.67	1.71	1.74	1.76
40	1 P frigorifique	(Watt)	853	1288	1796	2387	3075	3870	4785	5832	7023
	2 P absorbée	(W)	602	740	862	972	1075	1176	1277	1385	1502
	3 I absorbée	(A)	1.16	1.39	1.58	1.76	1.90	2.03	2.15	2.26	2.36
50	1 P frigorifique	(Watt)		948	1383	1886	2468	3142	3919	4812	5832
	2 P absorbée	(W)		708	866	1011	1148	1279	1411	1548	1693
	3 I absorbée	(A)		1.27	1.56	1.83	2.07	2.29	2.49	2.68	2.86
60	1 P frigorifique	(Watt)			1048	1466	1946	2502	3145	3887	4741
	2 P absorbée	(W)			871	1052	1222	1387	1551	1718	1891
	3 I absorbée	(A)			1.43	1.79	2.13	2.44	2.72	3.00	3.26

60 Hz R513A											
											N°User-358
4 T condensation	5 T évaporation	(°C)	-25	-20	-15	-10	-5	0	5	10	15
30	1 P frigorifique	(Watt)	1422	2053	2765	3574	4492	5534	6713	8044	9540
	2 P absorbée	(W)	794	905	1001	1088	1172	1259	1355	1465	1594
	3 I absorbée	(A)	1.20	1.37	1.53	1.67	1.81	1.95	2.10	2.25	2.42
40	1 P frigorifique	(Watt)	940	1524	2177	2913	3746	4691	5760	6968	8329
	2 P absorbée	(W)	755	911	1049	1174	1291	1406	1525	1654	1798
	3 I absorbée	(A)	1.10	1.33	1.54	1.74	1.93	2.11	2.29	2.48	2.67
50	1 P frigorifique	(Watt)		1046	1622	2268	2999	3829	4771	5839	7047
	2 P absorbée	(W)		858	1050	1224	1385	1541	1695	1855	2025
	3 I absorbée	(A)		1.27	1.54	1.80	2.04	2.26	2.49	2.71	2.94
60	1 P frigorifique	(Watt)			1153	1693	2305	3002	3799	4710	5747
	2 P absorbée	(W)			993	1228	1446	1653	1855	2058	2267
	3 I absorbée	(A)			1.52	1.84	2.13	2.42	2.69	2.95	3.22

1 = cooling capacity 2 = power input 3 = current 4 = condensing temperature 5 = evaporating temperature

Nota : Tecumseh se réserve le droit de modifier les informations contenues dans ce document sans préavis.

Note : Tecumseh reserves the right to change information contained in this document without notification.

© 2021 Tecumseh Products Company
All rights reserved