



Compressor
Voltage Code : GZ

CAJ4519T-GZ

High Temp. Commercial (HP)

208 - 220V 1~ 50 Hz

R22

AJ4519T-GZ3C

Conditions	Frequency	Nominal Cooling Capacity		Sound Power ISO3745 / ISO 3743-1
		Watts	BTU/h	
EN12900_MHP / R22	50 Hz	2768	9438	

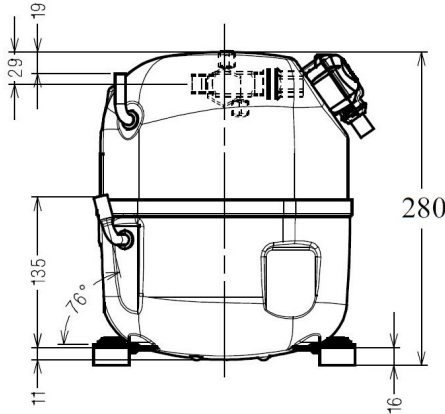

Displacement (cc)	34,45
Net Weight (Kg)	22.6
Oil Quantity (cc)	475.0
Oil Type	Mineral
Expansion Device	Capillary_Tube/Expansion_Valve
Cooling	Fan
Main Winding (Ohm)	1.24
Start Winding (Ohm)	5.3
Current	
RLA (A)	8.9
MCC (A)	12.9
LRA (A)	44
Electrical Equipment	CSR
Overload	MST00AHW
Time Check	2.8s - 5.2s / 33.5 A
Open Temp	135° C
Close Temp	61° C
Optional	T0478
Start Capacitor	100 µF / 250 V
Run Capacitor	35 µF / 400 V
Potential Relay	RVA4AI**
Pick Up	204/233V
Drop Out	60/121V
Refrigerating connection for OD	
Suction Tube	15.9 (5/8")
Discharge Tube	9.5 (3/8")
Process Tube	6.35 (1/4")

* EN12900_MHP : T°Cond. 45.0°C / T°Evap. -10.0°C / T°Return gas temp.. 20.0°C
T°Subcooling. 0.0K

Certificates :



Note : Tecumseh reserves the right to change information contained in this document without notification.



Tecumseh

CAJ4519T-GZ	Tension GZ : 208 - 220V 1~ 50 Hz
--------------------	---

Les performances sont données dans les conditions EN12900_MHP :	Gaz aspirés :	20.0 °C
Condition Dew	Sous refroidissement :	0.0 K
The performance data are in EN12900_MHP conditions :	Return gas :	20.0 °C
Dew Condition	Subcooling :	0.0 K

50 Hz R22

N°2517

4 T condensation	5 T évaporation	(°C)	-20	-15	-10	-5	0	5	10	15
40	1 P frigorifique	(Watt)	1971	2462	3039	3700	4441	5260	6155	7121
	2 P absorbée	(W)	1228	1315	1401	1484	1566	1645	1723	1798
	3 I absorbée	(A)	5.85	6.30	6.73	7.14	7.53	7.89	8.23	8.55
50	1 P frigorifique	(Watt)	1535	1975	2489	3076	3731	4453	5238	6083
	2 P absorbée	(W)	1160	1303	1439	1569	1692	1807	1916	2018
	3 I absorbée	(A)	5.51	6.16	6.78	7.38	7.96	8.51	9.03	9.53
60	1 P frigorifique	(Watt)		1462	1923	2443	3022	3655	4339	5071
	2 P absorbée	(W)		1290	1478	1654	1818	1971	2112	2241
	3 I absorbée	(A)		6.04	6.85	7.64	8.39	9.13	9.83	10.5

© 2021 Tecumseh Products Company
All rights reserved

1 = cooling capacity 2 = power input 3 = current 4 = condensing temperature 5 = evaporating temperature

Nota : Tecumseh se réserve le droit de modifier les informations contenues dans ce document sans préavis.

Note : Tecumseh reserves the right to change information contained in this document without notification.