



Compressor
Voltage Code : TZ

TAG4553T

High Temp. Commercial (HP)

400V 3~ 50Hz / 440V 3~ 60 Hz

R22

AGB4553TTZ

Conditions	Frequency	Nominal Cooling Capacity		Sound Power ISO3745 / ISO 3743-1
		Watts	BTU/h	
EN12900_MHP / R22	50 Hz / 60 Hz	6408 / 7612	21851 / 25956	77 dBA

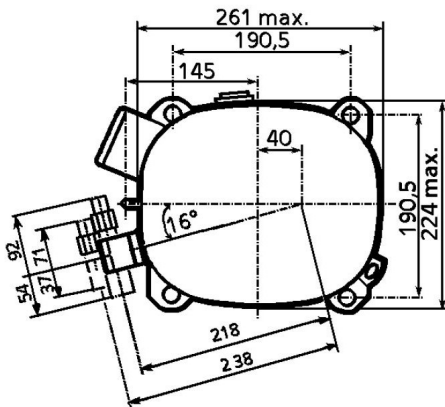
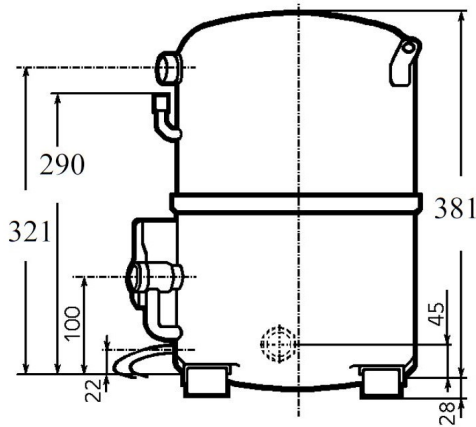

Displacement (cc)	100,7
Net Weight (Kg)	46.0
Oil Quantity (cc)	1760.0
Oil Type	Mineral
Expansion Device	Capillary_Tube/Expansion_Valve
Cooling	Fan
Main Winding (Ohm)	3.6
Current	
RLA (A)	7.4 8
MCC (A)	12 12
LRA (A)	45 48
Electrical Equipment	TRI
Overload	Interne
Refrigerating connection for OD	
Suction Tube	22.2 (7/8")
Discharge Tube	15.9 (5/8")
Process Tube	6.35 (1/4")

* EN12900_MHP : T°Cond. 45.0°C / T°Evap. -10.0°C / T°Return gas temp.. 20.0°C
T°Subcooling. 0.0K

Certificates :



Note : Tecumseh reserves the right to change information contained in this document without notification.



Tecumseh

TAG4553T	Tension TZ : 400V 3~ 50Hz / 440V 3~ 60 Hz
-----------------	--

Les performances sont données dans les conditions EN12900_MHP :	Gaz aspirés :	20.0 °C
Condition Dew	Sous refroidissement :	0.0 K
The performance data are in EN12900_MHP conditions :	Return gas :	20.0 °C
Dew Condition	Subcooling :	0.0 K

50 Hz R22										
N°237EU-T										
4 T condensation	5 T évaporation	(°C)	-20	-15	-10	-5	0	5	10	15
40	1 P frigorifique	(Watt)	3938	5394	7107	9098	11387	13993	16931	20218
	2 P absorbée	(W)	2223	2548	2846	3126	3398	3671	3956	4261
	3 I absorbée	(A)	4.33	4.87	5.37	5.84	6.29	6.70	7.09	7.44
50	1 P frigorifique	(Watt)	2954	4228	5731	7483	9503	11807	14412	17330
	2 P absorbée	(W)	2081	2492	2880	3253	3622	3995	4383	4795
	3 I absorbée	(A)	4.16	4.79	5.41	6.02	6.62	7.21	7.79	8.36
60	1 P frigorifique	(Watt)		3161	4452	5964	7713	9716	11986	14534
	2 P absorbée	(W)		2468	2963	3446	3928	4418	4926	5461
	3 I absorbée	(A)		4.73	5.46	6.21	6.97	7.73	8.50	9.28

60 Hz R22										
N°237EU-T										
4 T condensation	5 T évaporation	(°C)	-20	-15	-10	-5	0	5	10	15
40	1 P frigorifique	(Watt)	4671	6413	8466	10851	13588	16697	20194	24094
	2 P absorbée	(W)	2783	3210	3607	3981	4337	4683	5026	5371
	3 I absorbée	(A)	8.97	10.1	11.2	12.3	13.4	14.5	15.6	16.7
50	1 P frigorifique	(Watt)	3489	4999	6792	8887	11306	14064	17177	20658
	2 P absorbée	(W)	2639	3163	3665	4152	4631	5108	5590	6083
	3 I absorbée	(A)	8.61	9.94	11.3	12.7	14.2	15.6	17.2	18.7
60	1 P frigorifique	(Watt)		3734	5265	7071	9169	11576	14304	17362
	2 P absorbée	(W)		3133	3744	4348	4952	5564	6188	6833
	3 I absorbée	(A)		9.80	11.4	13.1	14.9	16.8	18.7	20.8

1 = cooling capacity 2 = power input 3 = current 4 = condensing temperature 5 = evaporating temperature

Nota : Tecumseh se réserve le droit de modifier les informations contenues dans ce document sans préavis.
Note : Tecumseh reserves the right to change information contained in this document without notification.

© 2021 Tecumseh Products Company
All rights reserved