



Compressor
Voltage Code : TZ

TAG4561T

High Temp. Commercial (HP)

400V 3~ 50Hz / 440V 3~ 60 Hz

R22

AGB4561TTZ

Conditions	Frequency	Nominal Cooling Capacity		Sound Power ISO3745 / ISO 3743-1
		Watts	BTU/h	
EN12900_HP / R22	50 Hz / 60 Hz	13705 / 16140	46733 / 55039	77 dBA

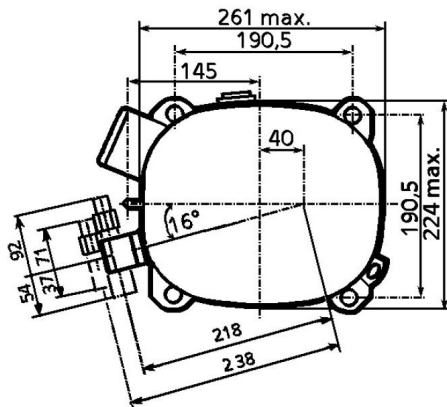
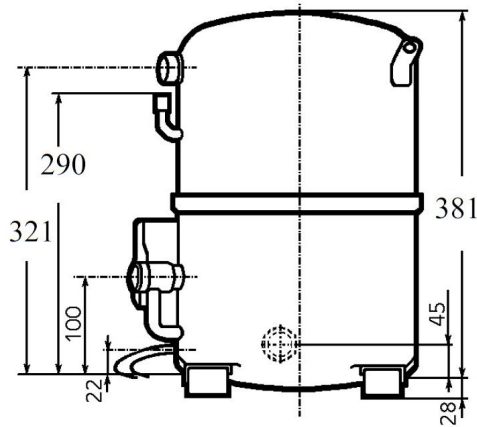

Displacement (cc)	112,5
Net Weight (Kg)	46.0
Oil Quantity (cc)	1760.0
Oil Type	Mineral
Expansion Device	Capillary_Tube/Expansion_Valve
Cooling	Fan
Main Winding (Ohm)	3.2
Current	
RLA (A)	9 9.9
MCC (A)	15 15
LRA (A)	51 53
Electrical Equipment	TRI
Overload	Interne
Refrigerating connection for OD	
Suction Tube	28.6 (1"1/8)
Discharge Tube	15.9 (5/8")
Process Tube	6.35 (1/4")

* EN12900_HP : T°Cond. 50.0°C / T°Evap. 5.0°C / T°Return gas temp.. 20.0°C
T°Subcooling. 0.0K

Certificates :



Note : Tecumseh reserves the right to change information contained in this document without notification.



Tecumseh

TAG4561T	Tension TZ : 400V 3~ 50Hz / 440V 3~ 60 Hz
-----------------	--

Les performances sont données dans les conditions EN12900_HP :	Gaz aspirés :	20.0 °C
Condition Dew	Sous refroidissement :	0.0 K
The performance data are in EN12900_HP conditions :	Return gas :	20.0 °C
Dew Condition	Subcooling :	0.0 K

50 Hz R22										
N°237GU-T										
4 T condensation	5 T évaporation	(°C)	-20	-15	-10	-5	0	5	10	15
40	1 P frigorifique	(Watt)	4653	6257	8181	10451	13093	16132	19589	23485
	2 P absorbée	(W)	2598	2975	3340	3686	4008	4297	4549	4757
	3 I absorbée	(A)	5.37	6.08	6.71	7.24	7.69	8.05	8.32	8.50
50	1 P frigorifique	(Watt)	3539	4927	6612	8620	10977	13705	16822	20346
	2 P absorbée	(W)	2474	2923	3377	3829	4274	4703	5112	5492
	3 I absorbée	(A)	5.16	6.00	6.77	7.47	8.10	8.66	9.16	9.59
60	1 P frigorifique	(Watt)		3664	5097	6831	8890	11292	14056	17194
	2 P absorbée	(W)		2881	3427	3988	4558	5130	5698	6254
	3 I absorbée	(A)		5.92	6.83	7.70	8.51	9.28	10.00	10.7

60 Hz R22										
N°237GU-T										
4 T condensation	5 T évaporation	(°C)	-20	-15	-10	-5	0	5	10	15
40	1 P frigorifique	(Watt)	5565	7455	9714	12372	15459	19002	23024	27549
	2 P absorbée	(W)	2706	3332	3964	4568	5112	5563	5887	6053
	3 I absorbée	(A)	9.18	11.1	12.8	14.4	15.8	17.0	18.1	19.0
50	1 P frigorifique	(Watt)	4236	5873	7854	10208	12962	16140	19766	23858
	2 P absorbée	(W)	2578	3282	4014	4739	5426	6042	6553	6927
	3 I absorbée	(A)	8.82	10.9	12.9	14.8	16.6	18.3	19.9	21.4
60	1 P frigorifique	(Watt)		4369	6056	8090	10495	13295	16509	20150
	2 P absorbée	(W)		3247	4098	4965	5815	6615	7332	7934
	3 I absorbée	(A)		10.8	13.1	15.3	17.5	19.6	21.8	23.8

1 = cooling capacity 2 = power input 3 = current 4 = condensing temperature 5 = evaporating temperature

Nota : Tecumseh se réserve le droit de modifier les informations contenues dans ce document sans préavis.
Note : Tecumseh reserves the right to change information contained in this document without notification.

© 2021 Tecumseh Products Company
All rights reserved