



Compressor
Voltage Code : FZ

FH4524F

High Temp. Commercial (HP)

220 - 240V 1~ 50 Hz

R22

AHC4524EFZ

Conditions	Frequency	Nominal Cooling Capacity		Sound Power ISO3745 / ISO 3743-1
		Watts	BTU/h	
EN12900_HP / R22	50 Hz	5287	18030	73 dBA

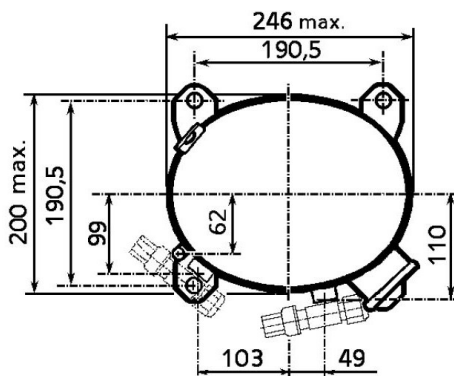
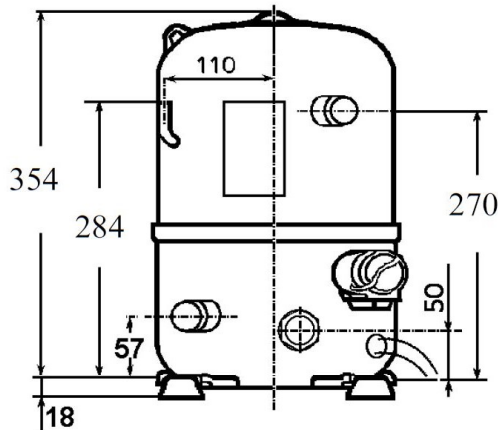

Displacement (cc)	43,5
Net Weight (Kg)	34.0
Oil Quantity (cc)	1330.0
Oil Type	Mineral
Expansion Device	Capillary_Tube/Expansion_Valve
Cooling	Fan
Main Winding (Ohm)	1.17
Start Winding (Ohm)	3.85
Current	
RLA (A)	9.6
MCC (A)	13.8
LRA (A)	51
Electrical Equipment	CSR
Overload	Interne
Start Capacitor	100 µF / 330 V
Run Capacitor	30 µF / 400 V
Potential Relay	RVA4I**
Pick Up	204/233V
Drop Out	50/110V
Optional	3ARR3*6AU*
Refrigerating connection for OD	
Suction Tube	15.9 (5/8")
Discharge Tube	12.7 (1/2")
Process Tube	6.35 (1/4")

* EN12900_HP : T°Cond. 50.0°C / T°Evap. 5.0°C / T°Return gas temp.. 20.0°C
T°Subcooling. 0.0K

Certificates :



Note : Tecumseh reserves the right to change information contained in this document without notification.



Tecumseh

FH4524F	Tension FZ : 220 - 240V 1~ 50 Hz
----------------	---

Les performances sont données dans les conditions EN12900_HP : Condition Dew	Gaz aspirés : 20.0 °C Sous refroidissement : 0.0 K
The performance data are in EN12900_HP conditions : Dew Condition	Return gas : 20.0 °C Subcooling : 0.0 K

50 Hz R22

N°236ET-F

4 T condensation	5 T évaporation	(°C)	-20	-15	-10	-5	0	5	10	15
40	1 P frigorifique	(Watt)	2012	2545	3240	4091	5095	6246	7539	8969
	2 P absorbée	(W)	1348	1458	1567	1676	1784	1891	1997	2103
	3 I absorbée	(A)	5.46	6.20	6.87	7.49	8.04	8.54	8.98	9.36
50	1 P frigorifique	(Watt)	1576	2044	2654	3401	4281	5287	6416	7660
	2 P absorbée	(W)	1272	1444	1610	1771	1927	2077	2222	2361
	3 I absorbée	(A)	5.13	6.05	6.92	7.74	8.50	9.20	9.85	10.4
60	1 P frigorifique	(Watt)		1512	2048	2702	3468	4340	5314	6383
	2 P absorbée	(W)		1429	1653	1867	2071	2265	2449	2623
	3 I absorbée	(A)		5.93	6.99	8.00	8.96	9.87	10.7	11.5

© 2021 Tecumseh Products Company
All rights reserved

1 = cooling capacity 2 = power input 3 = current 4 = condensing temperature 5 = evaporating temperature

Nota : Tecumseh se réserve le droit de modifier les informations contenues dans ce document sans préavis.

Note : Tecumseh reserves the right to change information contained in this document without notification.