



Compressor
Voltage Code : FZ

FH4522Z

High Temp. Commercial (HP)

220 - 240V 1~ 50 Hz

R452A / R404A / R449A

AHC4522ZFZ

Conditions	Frequency	Nominal Cooling Capacity		Sound Power ISO3745 / ISO 3743-1
		Watts	BTU/h	
EN12900_MHP / R452A	50 Hz	2588	8825	71 dBA
EN12900_MHP / R404A	50 Hz	2662	9077	71 dBA
EN12900_MHP / R449A	50 Hz	2457	8377	71 dBA

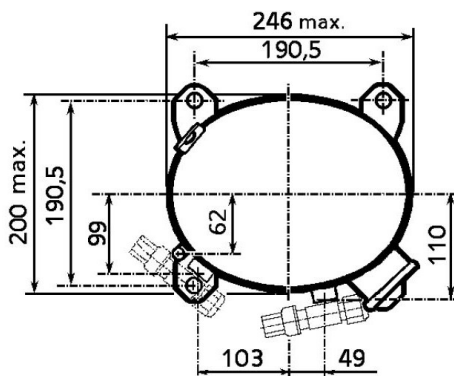
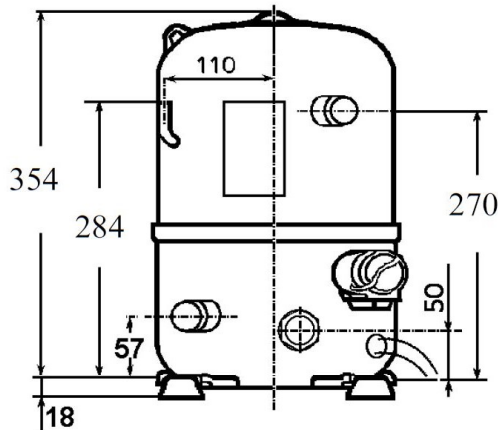

Displacement (cc)	39,9
Net Weight (Kg)	32.0
Oil Quantity (cc)	1330.0
Oil Type	Polyolester
Expansion Device	Capillary_Tube/Expansion_Valve
Cooling	Fan
Main Winding (Ohm)	1.3
Start Winding (Ohm)	4.2
Current	
RLA (A)	9.7
MCC (A)	16
LRA (A)	46
Electrical Equipment	CSR
Overload	Interne
Start Capacitor	125 µF / 330 V
Run Capacitor	30 µF / 400 V
Potential Relay	RVA4I**
Pick Up	204/233V
Drop Out	50/110V
Optional	3ARR3*6AU*
Refrigerating connection for OD	
Suction Tube	15.9 (5/8")
Discharge Tube	12.7 (1/2")
Process Tube	6.35 (1/4")

* EN12900_MHP : T°Cond. 45.0°C / T°Evap. -10.0°C / T°Return gas temp.. 20.0°C
T°Subcooling. 0.0K

Certificates :



Note : Tecumseh reserves the right to change information contained in this document without notification.



Tecumseh

FH4522Z	Tension FZ : 220 - 240V 1~ 50 Hz
----------------	---

Les performances sont données dans les **conditions EN12900_MHP** :
 Condition Dew
 The performance data are in **EN12900_MHP conditions** :
 Dew Condition

Gaz aspirés : 20.0 °C
 Sous refroidissement : 0.0 K
 Return gas : 20.0 °C
 Subcooling : 0.0 K

50 Hz R452A											
											N°2106
4 T condensation	5 T évaporation	(°C)	-25	-20	-15	-10	-5	0	5	10	15
30	1 P frigorifique	(Watt)	1554	2131	2819	3634	4592	5708	7000	8482	10171
	2 P absorbée	(W)	956	1102	1233	1354	1466	1573	1678	1785	1895
	3 I absorbée	(A)	4.48	5.08	5.64	6.17	6.66	7.12	7.54	7.92	8.28
40	1 P frigorifique	(Watt)		1629	2231	2935	3755	4708	5809	7075	8521
	2 P absorbée	(W)		1096	1271	1430	1575	1710	1838	1962	2085
	3 I absorbée	(A)		5.05	5.78	6.48	7.14	7.78	8.37	8.94	9.47
50	1 P frigorifique	(Watt)			1655	2245	2926	3713	4623	5670	6872
	2 P absorbée	(W)			1253	1467	1662	1842	2010	2168	2320
	3 I absorbée	(A)			5.72	6.60	7.44	8.25	9.03	9.77	10.5
60	1 P frigorifique	(Watt)				1576	2115	2735	3450	4278	5233
	2 P absorbée	(W)				1397	1659	1900	2124	2333	2530
	3 I absorbée	(A)				6.52	7.54	8.53	9.49	10.4	11.3

50 Hz R404A											
											N°226CT-F
4 T condensation	5 T évaporation	(°C)	-25	-20	-15	-10	-5	0	5	10	15
30	1 P frigorifique	(Watt)	1657	2246	2944	3766	4725	5838	7120	8584	10246
	2 P absorbée	(W)	1013	1163	1297	1419	1531	1637	1740	1843	1949
	3 I absorbée	(A)	4.75	5.36	5.93	6.46	6.96	7.41	7.81	8.18	8.51
40	1 P frigorifique	(Watt)	1188	1715	2323	3027	3840	4780	5859	7094	8499
	2 P absorbée	(W)	961	1161	1340	1500	1646	1780	1905	2024	2141
	3 I absorbée	(A)	4.56	5.35	6.09	6.80	7.47	8.09	8.68	9.22	9.72
50	1 P frigorifique	(Watt)		1201	1718	2303	2970	3734	4611	5615	6761
	2 P absorbée	(W)		1088	1328	1544	1740	1918	2082	2234	2379
	3 I absorbée	(A)		5.14	6.07	6.95	7.79	8.59	9.35	10.1	10.7
60	1 P frigorifique	(Watt)			1142	1607	2126	2715	3388	4160	5047
	2 P absorbée	(W)			1191	1479	1742	1981	2200	2403	2591
	3 I absorbée	(A)			5.85	6.90	7.92	8.90	9.83	10.7	11.6

1 = cooling capacity 2 = power input 3 = current 4 = condensing temperature 5 = evaporating temperature

Nota : Tecumseh se réserve le droit de modifier les informations contenues dans ce document sans préavis.

Note : Tecumseh reserves the right to change information contained in this document without notification.

© 2021 Tecumseh Products Company
All rights reserved



Tecumseh

FH4522Z	Tension FZ : 220 - 240V 1~ 50 Hz
----------------	---

Les performances sont données dans les conditions EN12900_MHP :	Gaz aspirés :	20.0 °C
Condition Dew	Sous refroidissement :	0.0 K
The performance data are in EN12900_MHP conditions :	Return gas :	20.0 °C
Dew Condition	Subcooling :	0.0 K

50 Hz R449A (*)

N°2221

4 T condensation	5 T évaporation	(°C)	-25	-20	-15	-10	-5	0	5	10	15
30	1 P frigorifique	(Watt)	1369	1925	2593	3390	4336	5447	6741	8236	9948
	2 P absorbée	(W)	891	1025	1149	1264	1373	1477	1579	1680	1783
	3 I absorbée	(A)	4.18	4.73	5.26	5.76	6.24	6.68	7.09	7.46	7.79
40	1 P frigorifique	(Watt)		1478	2068	2765	3586	4550	5674	6975	8472
	2 P absorbée	(W)		1029	1192	1342	1482	1611	1734	1851	1965
	3 I absorbée	(A)		4.74	5.42	6.08	6.72	7.33	7.90	8.43	8.92
50	1 P frigorifique	(Watt)			1558	2155	2854	3672	4627	5737	7020
	2 P absorbée	(W)			1184	1388	1577	1751	1914	2066	2210
	3 I absorbée	(A)			5.41	6.25	7.06	7.84	8.59	9.31	9.98
60	1 P frigorifique	(Watt)				1579	2157	2831	3620	4540	5609
	2 P absorbée	(W)				1328	1585	1824	2045	2252	2445
	3 I absorbée	(A)				6.20	7.21	8.19	9.14	10.1	10.9

© 2021 Tecumseh Products Company
All rights reserved

1 = cooling capacity 2 = power input 3 = current 4 = condensing temperature 5 = evaporating temperature

(*) Veuillez vous référer strictement aux Recommandations d'Utilisation et Bulletins Marketing Tecumseh du fait de la température de refoulement élevée pour les applications LBP.
(*) Due to very high discharge temperature especially on LBP conditions, please strictly refer to Tecumseh Guidelines & Marketing Bulletin when using this refrigerant.

Nota : Tecumseh se réserve le droit de modifier les informations contenues dans ce document sans préavis.

Note : Tecumseh reserves the right to change information contained in this document without notification.